

CONTENTS

2

SECONDARY CURRENT INJECTION (SCITS)

Single Phase

- 2 200ADM-P 200 Amp
- 6 50ADM-P 50 Amp
- 8 100ADM mk5 100 Amp
- 10 100A/E mk3 100 Amp
- 12 100ADM-F Current filter
- 13 RB10 Resistor box

Three Phase

- 14 50A-3PH mk2 50 Amp
- 16 200A-3PH mk3 200 Amp
- 18 1200A-3PH 1200 Amp

20

RELAY TEST EQUIPMENT

- 20 ART3V Three-phase Voltage Source

22

PRIMARY CURRENT INJECTION (PCITS)

- 22 750ADM-H mk3 750 Amp
- 24 PCU1-SP mk2 5kA 11kVA
- 26 CU-Ps 10kA 20kVA

29

DISCHARGE PROBES AND EARTH STICKS

- 29 DP20 Discharge probe
- 29 DP40 Discharge probe
- 29 ES30 Earth stick
- 29 ES50 Earth stick
- 29 ES100 Earth stick

30

CABLE / OVERHEAD LINE IMPEDANCE TEST SYSTEM

- 30 Z-OVR

32

HIGH VOLTAGE AC TEST SYSTEMS

- 32 KV5-100 mk3 5kV 100mA
- 34 KV30-40D mk3 30kV 40mA
- 36 VC24-24 mk2 24kV 24mA
- 38 KV50-20D mk3 50kV 20mA
- 40 KV30-100 mk3 30kV 100mA
- 40 KV50-100 mk3 50kV 100mA
- 42 KV50-200 mk3 5kV 200mA
- 42 KV100-100 mk3 100kV 100mA
- 44 HV Trolley2 3-15kV 20kVA

46

DC CABLE TEST SETS

- 46 PT18-10 mk3 +/-18kV
- 46 PT30-10 mk3 +/-30kV

48

DIGITAL MICRO-OHMMETERS

- 48 DMO200 200 Amp
- 50 DMO600 600 Amp

200ADM-P

Current Injection System with Phase Shift



FEATURES

- 0-200A output current
- True RMS metering with 1 cycle capture
- Variable auxiliary AC voltage/current output with phase shift
- Auxiliary metering: V, f, Φ , X, Z, P, S, PF, CT ratio, harmonics
- Variable auxiliary output 12-220VDC
- Multi-function auto-ranging timing system
- Current limit mode for fine control
- Data storage to USB memory key including waveform & harmonics
- USB keyboard/printer interface
- Automatic mains voltage selection

The 200ADM-P is a current injection system with a wide range of advanced features including phase shift, data storage and harmonic analysis.

The unit has a range of outputs allowing injection of currents between 1mA and 200A. Voltages up to 240V are available on the main outputs allowing high impedance current relays to be tested. True RMS metering with single cycle capture is provided. Four current ranges allow the full scale of the meter and trip level to be set independently of the selected output. Industry standard safety connectors are used throughout for safe, reliable convenience.

The 200ADM-P has a flexible auxiliary AC output that can be used at up to 260V for voltage relays or up to 10A for current relays. The phase and frequency of this output are fully adjustable. This combination of voltage and current allows testing of relays that require two voltages, one voltage and one current or two currents.

An auxiliary metering module is provided that meters AC and DC voltage, current and frequency from the auxiliary outputs or external signals. The module can also take measurements in conjunction with the main current output to meter phase angle, power, impedance, CT ratio and harmonics.

A variable stabilised DC supply with current limit is provided to power the relay under test.

The unit has a comprehensive timing system linked to the outputs allowing trip times, reset times and reclose times to be quickly measured to a high degree of accuracy. The timer includes a current operated mode and can test instantaneous trips.

Two USB host sockets are provided to connect a memory key, keyboard or printer. Results of every test can be stored to the memory key in spreadsheet format for later analysis. The keyboard allows entry of a comment against each result. In addition a graphics file of the waveform may be stored to the memory key. Harmonic analysis results can also be recorded.

200ADM-P Applications

IEEE No.	Type
21	Distance protection (phase at a time)
24	Volts/Hz
25	Check sync
27/59	Under/over voltage
32/P/Q	Directional power
37	Under-current/power
40	Field relay
46N	Negative sequence overcurrent relay
50/76	Instantaneous overcurrent
50	Ground fault relay
50V	Voltage restrained overcurrent
51	IDMT overcurrent relay
55	Power factor relay
59G	Neutral voltage displacement
67	Directional overcurrent
67N	Directional ground fault
78	Phase angle
79	Auto recloser
81	Under/over frequency
85	Pilot wire relay
86	Lockout relay
87	Differential relay
91	Directional voltage relay
92	Power directional relay
94	Tripping relay, Voltage regulating relay, Miniature circuit breakers, Thermal relays, CT mag curves

200ADM-P Specification

Main Output

The main output on the unit has four taps, allowing the selection of output voltages up to 240V and output currents up to 200A.

Current				Output @230V		
Range	Cont	5 min*	1 min*	6 sec**	O/C	Load V
10V	33A	67A	100A	200A	10.5V	8.7V@100A
35V	10A	20A	30A	-	36V	32V@30A
100V	3A	6A	10A	-	108V	99V@10A
240V	1A	2A	3A	-	276V	259V@3A
240V DC	1A	2A	3A	-		

Protection: over current trip, duty cycle trip, thermal monitoring.

*Off time of 15 minutes. On times based on an ambient temperature of 25°C.

**6 second intermittent ratings available with 230V supply.

Auxiliary Metering

The auxiliary metering input on the 200ADM-P measures AC and DC voltage and current. The input is rated for 300V RMS or 5/10A RMS (10A for waveforms with a Crest Factor up to 1.5; 5A RMS for a CF of 3).

The module can take measurements using the main output and auxiliary input together to measure phase angle, power, impedance and CT ratio (for both 1A and 5A CTs). It can also analyse the harmonic content of the main output and auxiliary input up to 31st harmonic and calculate the THD of the waveform. Measurements may be logged to the USB key.

DC: Volts/Amps DC average & RMS ripple
 AC: Volts/Amps AC RMS, frequency & phase angle
 Power: S (VA), P (W) and power factor
 Impedance: Z, X & phase angle (Φ)
 CT ratio: Ratio relative to 1A & 5A CT and phase angle
 Harmonic: Harmonics & THD main output & aux input

Setting	Range	Resolution	Accuracy
VDC/AC rms	300.0V	0.1V	$\pm 0.7\% \text{rdg} \pm 5d$
Idc/AC rms	5.000A CF<3 9.999A CF<1.5	0.001A	$\pm 0.7\% \text{rdg} \pm 5d$
Phase	-179.9°— +180.0°	0.1°	$\pm 3^\circ$
Frequency	40—100Hz	0.01Hz	$\pm 0.02\% \text{rdg} \pm 1d$

Protection: fuse on current input.

Auxiliary AC Output and its Applications

The auxiliary AC output supplies an extra isolated voltage or current to the relay under test. The output is a digitally generated pure sine wave, and three ranges (two voltage and one current) are provided for maximum flexibility.

The output is adjustable from zero and can be phase shifted through 360°. It is also linked to the timer circuit.

Range	Maximum Output			
	Voltage	Current	Current	Current
0-130V	144V	125V	0.23A	0.46A
0-260V	288V	250V	0.11A	0.23A
0-6V	6.6V	5V	5A	10A

Frequency range: 45 - 100Hz

Phase angle: 0 - $\pm 180^\circ$

Protection: current limit and electronic trip.

1 Voltage — Over/Under Voltage Relays

Testing over and under voltage relays with the 200ADM-P is simple—even checking delay times. Connect the main output in series with the auxiliary output to generate voltage steps with timing.

1 Voltage — Frequency Relays

The auxiliary AC output can be either phase locked to the supply or switched to variable frequency mode. Operating points are easily determined and the response of the relay timed.

1 Voltage + 1 Current — Various Relays

The phase shifting capability of the auxiliary output is ideal for testing directional overcurrent and earth fault relays. The main output is used to inject current and the auxiliary supplies the voltage coil. The same configuration is used to test reverse power relays and phase at a time testing of distance protection. Test of these relays is eased further by direct display of W, VA, phase angle and impedance. Testing an Automatic Voltage Regulating (AVR) relay with line drop compensation also requires a current and voltage with phase-shift. The two contact inputs can be used to show the state of the up/down contacts on the relay.

2 Currents — Bias Differential Relay

The 10A auxiliary AC output can be used to supply a second current to the relay under test as required by differential protection. This output, independent of the mains, can be used when a stabilised current is required.

2 Voltages — Check Sync Relay

The combination of the main output used as a voltage source and the auxiliary AC output meets the requirements of Check-Sync testing. With the auxiliary output set to variable frequency different frequencies may be applied to the relay inputs for checking the frequency matching function of the relay. Switching to phase lock mode then allows the phase check function of the relay to be tested.

Timing System

Each contact circuit will auto-select for normally open or normally closed contacts. A DC voltage of 24—240VDC may also be used to trigger either timer channel. Contact state is shown by an LED.

Mode	Timer Start	Timer Stop
Internal start	Press 'ON'	Contact 1 or 2
1 contact	Contact 1 1st change	Contact 1 2nd change
2 contacts	Contact 1 change	Contact 2 change
Current operated	Current > 10% of metering range	Current < 10% of metering range
Pulse	Press 'ON'	200ms
Aux AC	Aux AC on/ switch freq to Φ / switch Φ to freq	Contact 1 or 2 change

For example, to time an IDMT current relay the relay contacts are connected to Contact set 1 and “internal start” mode is selected. When the main output is switched on, current injection and the timer starts. When the relay trips the timer stops and the output is switched off. All contacts are sensitive to changes of state rather than setting for normally open or normally closed. At the end of a test when the timer stops the output is switched off to safeguard the relay under test. LEDs indicate the contact state.

Setting the timer to AUX AC starts the timer when the auxiliary AC output is switched on or the output is switched from variable frequency to phase control or vice versa. This is ideal for testing trip times on under or over voltage protection and testing Check Sync Relays.

In addition the unit will time between changes on one set of contacts or two sets of contacts. Current operated mode starts and stops the timer on the rise and fall of current on the main output. This mode will test devices where the breaking contacts are in series with the sense circuit, as in thermal or thermal-magnetic circuit breakers.

Pulse mode is used for setting the current level in devices sensitive to heating. Current is injected for 200ms and the current recorded.

Timing System	
Range	0-999.999s/9999.99s/99999.9s autoranging
Resolution	1/10/100ms
Accuracy	0.01%rdg+2d (+4d current operated mode)
Contact o/c	24V
Contact s/c	20mA
VDC	24 - 240V

Metering

The output is metered by a digital true RMS system with a single cycle capture memory ammeter—whenever the timer stops and the output is switched off, the current reading is held on the display. A current trip is set to 110% of full scale of the selected metering range.

I Limit Mode

The 200ADM-P has a current limit function for the main output that gives very fine current control for currents up to 10A. Low impedance loads such as microprocessor relays present no problem to the 200ADM-P, currents can be accurately controlled down to a few mA.

RS232 port for connection to a printer or PC and T&R Link contact output and phase lock connection for DVS3 Mk2.

Range	Current (A)				Output V @230V	
	Short circuit	Cont.	5 min	2 min	O/C	Load V
10V	10A	3A	6A	10A	8.6V	5V@5A
35V	3A	1A	2A	3A	29V	13V@2A
100V	1A	0.3A	0.6A	1A	88V	40V@0.6A
240V	0.3A	0.1A	0.2A	0.3A	224V	130V@0.2A

Safety

An earth terminal is provided for connection to a local earth. The unit is designed to comply with BSEN61010 and is CE marked.

Supply Requirements

115V/230V \pm 10% auto-selecting 50/60Hz 1ph, 2300VA max.

Temperature Range

Storage -20°C to 60°C Operating 0°C to 45°C

Dimensions

Peli case: 560 x 456 x 265mm;

Metal case: 380 x 314 x 221mm;

Weight

22.6kg

19.5kg

Accessories

The 200ADM-P is supplied with operating manual, output lead set, mains lead, spare fuses, USB keyboard, USB memory key.

Lead Set specifications

The 200ADM-P is supplied with a high quality lead set including:

- 2 x 5m 25mm² 200A leads terminated in M10 fork crimps
- 2 x 5m, 2 x 0.5m 2.5mm² 25A leads terminated in 4mm plugs
- 1 x 5m 2 core auxiliary leads terminated in 4mm plugs

Optional accessories

Filter unit, RB10 resistor box, printer, pushbutton lead for runback timing on disc induction relays.

Auxiliary DC Output

The 200ADM-P has a stabilised, variable DC output for powering the relay under test with an output of 12-220V in two ranges. The output is current limited and can supply loads requiring high inrush

Range	Maximum A	Continuous rating
12-60V	1A	25W
60-220V	0.23A	25W



currents.

The unit is also available in a metal case; this must be specified at the time of ordering

Storage of Results

All test results from the 200ADM-P can be stored in a USB memory key. The unit has a real-time clock to time and date-stamp all results. To log the results, first enter a comment for your results using the digital pot and arrow keys or optional keyboard, and then select AUTO STORE. Whenever the timer stops, the time, current and all other parameters are added to a spreadsheet file on the USB key. You can then view the current set of results on the display or take the USB key out and open the file on your PC.

All results are stored in a folder on the USB key named with the test date in a file named with the time.

Also, the 200ADM-P can store a .BMP file of the waveform to the USB key.

Sample data stored on USB key

Time	Date	Main A	Timer	Aux A	Aux V	Phase	Freq Hz	Comment
10:53:12	12/12/17	2.000	10.000	0.000	10.0	10.3	50.00	Overcurrent subl relay 12
10:53:30	12/12/17	5.000	3.000	0.000	10.0	10.3	50.00	Overcurrent subl relay 12
10:54:10	12/12/17	10.00	1.000	0.000	10.0	10.3	50.00	Overcurrent subl relay 12

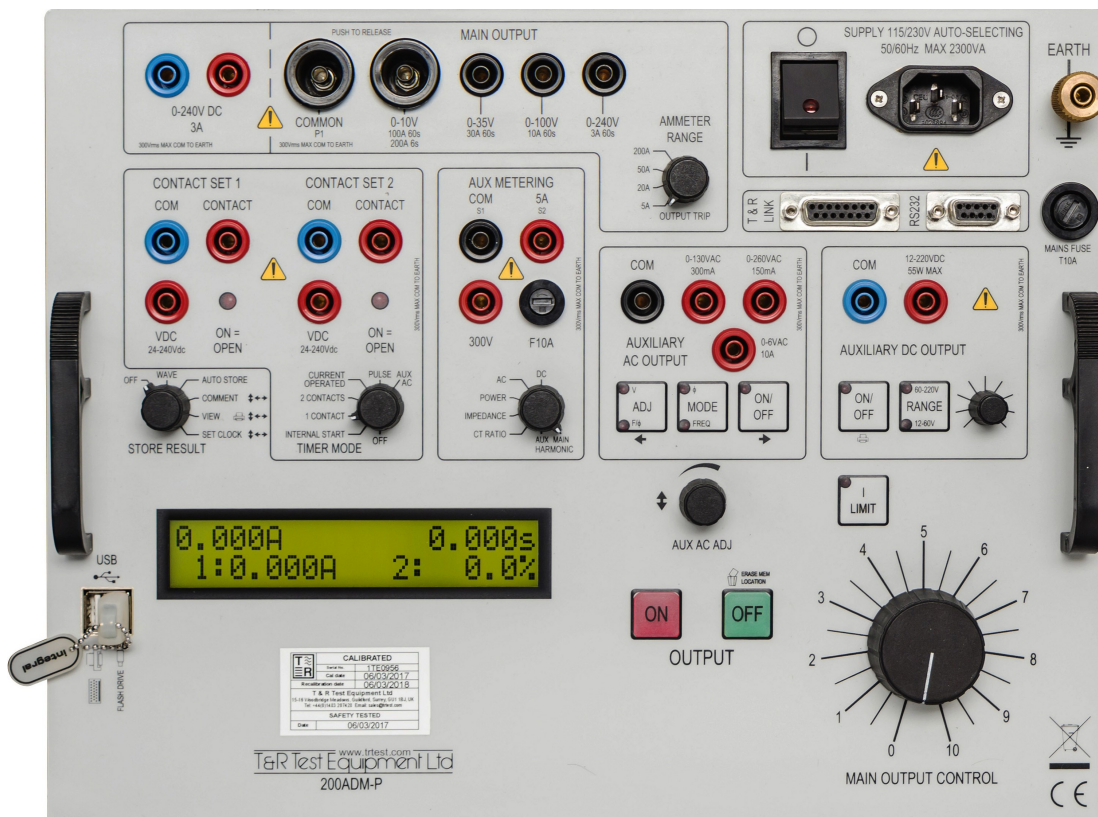

50ADM-P

Current Injection System with Phase Shift

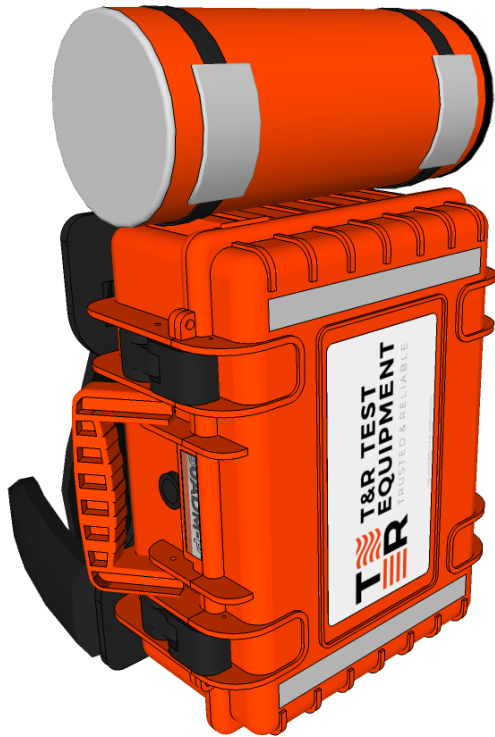

Features

- 0-50A output current
- True RMS metering with 1 cycle capture
- Variable auxiliary AC voltage/current output with phase shift
- Auxiliary metering input V, f, ϕ , Z, P, S, PF, CT ratio, harmonics
- Variable auxiliary output 12-220VDC
- Multi-function auto-range timing system
- Current limit mode for fine control
- Data storage to USB memory key including waveform & harmonics
- USB keyboard interface
- Automatic mains voltage selection
- Optional Backpack System

The 50ADM-P is a smaller version of our current injection system the 200ADM-P. The unit has a range of outputs allowing injection of currents from 1mA to 50A. Voltages up to 18V are available on the main outputs. True RMS metering with single cycle capture is provided. Three current ranges allow the full scale of the meter and trip level to be set independently of the selected output. Industry standard safety connectors are used throughout for safe, reliable convenience.

The 50ADM-P has a flexible auxiliary AC output that can be used at up to 260V for voltage relays or up to 10A for current relays. The phase and frequency of this output are fully adjustable. This combination of voltage and current allows testing of relays that require two voltages, one voltage and one current or two currents.

An auxiliary metering input is provided that meters AC and DC voltage, current and frequency from the auxiliary outputs or external signals. The module can also take measurements in conjunction with the main current output to meter phase angle, power, impedance, CT ratio and harmonics.

A variable stabilised DC supply with current limit is provided to power the relay under test. The unit has a comprehensive timing system linked to the outputs allowing trip times, reset times and reclose times to be quickly measured to a high degree of accuracy.



The timer includes a current operated mode and can accurately test instantaneous trips. Two USB host sockets are provided to connect a memory key and keyboard. Results of every test can be stored to the memory key in spreadsheet format for later analysis. The keyboard allows entry of a comment against each result. In addition a graphics file of the waveform may be stored to the memory key. Harmonic analysis results can also be recorded.

Main Output

The main output on the unit has two taps, allowing the selection of output voltages up to 18V and output currents up to 50A.

Range	Continuous	5 minutes	1 minute
3.5V	16A	32A	50A
18V	4A	8A	12A

The above intermittent on times must be followed by an off time of 15 minutes, based on an ambient temperature of 25°C.

Protection: over current trip, duty cycle trip, thermal monitoring.

Auxiliary DC Output

Protection: current limit.

Range	Maximum A	Continuous Rating
12-60V	1A	25W
60-220V	0.23A	25W

50ADM-P Specification

Metering

The output is metered by a digital true RMS system with a memory ammeter - whenever the timer stops and the output is switched off, the current reading is held on the display. The currents for each phase are displayed simultaneously.

A current trip is set to 110% of full scale of the selected metering range. A current trip is automatically set to 105% of full scale of the current metering range to protect the device under test.

Protection: over current trip, duty cycle trip, thermal monitoring.

Range	Resolution	Trip current	Accuracy
5.000A	0.001A	5.25A	$\pm 0.6\%rdg+5d$
20.00A	0.01A	21A	$\pm 0.6\%rdg+5d$
50.00A	0.01A	52.5A	$\pm 0.6\%rdg+5d$

I Limit Mode

The main output has a current limit mode that gives very fine control of output currents up to 10A. It also allows fine current control into very low impedance loads such as digital relays.

Auxiliary Metering Inputs

Protection: fuse on current input.

Setting	Range	Resolution	Accuracy
Volts AC	300.0V	0.1V	$\pm 0.7\%rdg+5d$
Amps AC	5.000A	1mA	$\pm 0.7\%rdg+5d$
Phase	$\pm 180^\circ$	0.1°	$\pm 3^\circ$
Frequency	20-1000Hz	0.1Hz	$\pm 0.2\%rdg+1d$

Timing System

Range 0-999.999s/9999.99s/99999.9s autoranging

Resolution 1/10/100ms

Accuracy 0.01%rdg+2d(+4d current operated mode)

Contact o/c 24V

Contact s/c 20mA

Vdc 24—240V

Mode	Timer Start	Timer Stop
Internal start	Press 'ON'	Contact 1 or 2 change
1 contact	Contact 1 1st change	Contact 1 2nd change
2 contacts	Contact 1 change	Contact 2 change
Current operated	Current > 10% of metering range	Current < 10% of metering range
Pulse	Press 'ON'	200ms
Aux AC	Aux AC on/ switch freq to ϕ / switch ϕ to freq	Contact 1 or 2 change

Supply Requirements

115V/230V $\pm 10\%$ auto-select 50/60Hz 1ph 2300VA max.

Dimensions

464 x 366 x 176mm

Weight

13kg without leads

Temperature Range

Storage -20°C to 60°C

Operating 0°C to 45°C

Accessories

The 50ADM-P is supplied with operating manual, output lead set, mains lead, spare fuses, USB keyboard, USB memory key, lead bag.

Lead Set specifications

The 50ADM-P is supplied with a high quality lead set including:

2 x 3m 10mm² 50A leads terminated in M10 fork crimps

2 x 5m, 2 x 0.5m 2.5mm² 25A leads terminated in 4mm plugs

1 x 5m 2 core auxiliary leads terminated in 4mm plugs.

Optional accessories

Filter unit, RB10 resistor box, pushbutton lead for run-back timing on disc induction relays, back-pack.

Safety

An earth terminal is provided for connection to a local earth. The unit is designed to comply with BSEN61010 and is CE marked.

50ADM-P Applications

IEEE no.	Type
21	Distance protection (phase at a time)
24	Volts/Hz
25	Check sync
27/59	Under/over voltage
32/P/Q	Directional power
37	Under-current/power
40	Field relay
46N	Negative sequence overcurrent relay
50/76	Instantaneous overcurrent
50	Ground fault relay
50V	Voltage restrained overcurrent
51	IDMT overcurrent relay
55	Power factor relay
59G	Neutral voltage displacement
67	Directional overcurrent
67N	Directional ground fault
78	Phase angle
79	Auto recloser
81	Under/over frequency
85	Pilot wire relay
86	Lockout relay
87	Differential relay
91	Directional voltage relay
92	Power directional relay
94	Tripping relay
	Voltage regulating relay
	Miniature circuit breakers
	Thermal relays
	CT mag curves

100ADM_{mk5}

Current Injection System



The 100ADM mk5 provides commissioning and maintenance engineers with a flexible system for testing protective systems. It has an easy to understand panel layout and simple user interface. The status of every function can be seen at a glance, and there are no complex menus to navigate.

The 100ADM mk5 keeps the familiar user interface of previous models but adds a new metering system that accurately measures the RMS of a single cycle. It also features a new current limit mode to provide very fine control of low currents, even into low impedance loads. Current limit mode also assists in testing self-powered overcurrent protection as fitted to many 11kV ring main units.

The unit has a range of outputs allowing injection of currents as low as a few mA and as high as 100A. Voltages up to 240V are available allowing high impedance current relays and voltage relays to be tested. Four true RMS metering ranges are provided, and the full scale of the meter (& trip level) can be set independently of output tap. Industry standard safety connectors are used on all inputs and outputs for convenience, reliability and safety.

A very flexible two channel timing system is provided, allowing trip times, reset times and reclose times to be quickly measured to a high degree of accuracy. The timer auto-ranges to measure from 1ms to 99999.9s.

The outputs of the 100ADM mk5 are well protected. The main output is protected by overcurrent, duty cycle and thermal trips. The auxiliary DC supply is protected by a current limit, and the auxiliary AC supply is fuse protected.

FEATURES

- Clear and simple user interface
- 0-100A output current
- Current limit mode for fine current control
- True RMS metering with single cycle capture memory ammeter
- Multi-function auto-ranging timing system
- Auxiliary DC and AC output
- Large back-lit liquid crystal display
- Thermal and over-current protection
- Compact and portable
- Automatic mains voltage selection

A 24-220VDC switch-mode stabilised DC supply with current limiting is provided to power the relay under test. An isolated, separately switched 110Vac auxiliary supply is also provided.



The back-lit display on the 100ADM mk5 is bright and clear with a wide viewing angle. The results of a test can be seen here as they appear on the display.

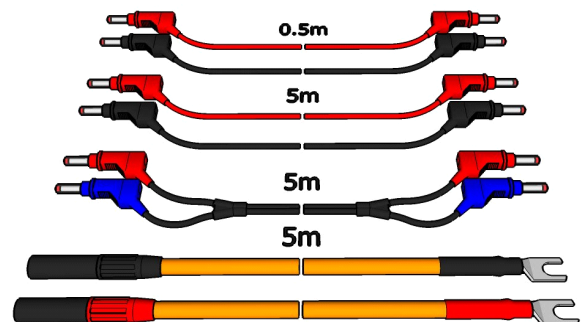

100ADM mk5 Applications

IEEE No.	Type
27/59	Under/over voltage
37	Undercurrent
50/76	Instantaneous overcurrent Ground fault relay
51	IDMT overcurrent relay
59G	Neutral voltage displacement
67	Directional overcurrent (basic tests)
79	Auto recloser
86	Lockout relay
94	Tripping relay
90V	Voltage regulating relay, Miniature circuit breakers, Circuit breakers for equipment, Thermal relays

100ADM mk5 Specification

Main Output

The main output on the unit has four taps, allowing the selection of output voltages up to 240V and output currents up to 100A.

Range	Current			Output V @230V	
	Cont	5 min*	1 min*	O/C	Load V
10V	33A	67A	100A	10.5V	8.7V@100A
35V	10A	20A	30A	36V	32V@30A
100V	3A	6A	10A	108V	99V@10A
240V	1A	2A	3A	276V	259V@3A
240VDC	1A	2A	3A		

*Off time of 15 minutes. On times based on ambient temperature of 25°C.

I Limit Mode

The main output has a current limit mode that gives very fine control of output currents up to 10A. It also allows fine current control into very low impedance loads such as digital relays.

Range	Current				Output V @230V	
	Short circuit	Cont.	5 min	2 min	O/C	Load V
10V	10A	3A	6A	10A	8.6V	5V@5A
35V	3A	1A	2A	3A	29V	13V@2A
100V	1A	0.3A	0.6A	1A	88V	40V@0.6
240V	0.3A	0.1A	0.2A	0.3A	224V	130V@0.2A

Auxiliary AC and DC Outputs

A switched, isolated auxiliary DC supply with current limit protection is available to power the relay under test, and a 110Vac auxiliary output is available for tests.

DC stabilised output	24V, 48V, 60V 110V, 220V	1.0A 0.23A
Fixed AC output	110Vac	300mA

Metering

The output is metered by a digital true RMS system with a single cycle capture memory ammeter—whenever the timer stops and the output is switched off, the reading is held on the display. A current trip is set to 110% of full scale of the selected metering range.

Range	Resolution	Trip current	Accuracy	Acquisition time
2.000A	0.001A	2.2A	±0.5%rdg±5d	20ms
10.00A	0.01A	11A	±0.5%rdg±5d	20ms
20.00A	0.01A	22A	±0.5%rdg±5d	20ms
100.0A	0.1A	110A	±0.5%rdg±5d	20ms

Timing System

Range	0-999.999s/9999.99s/99999.9s autoranging
Resolution	1/10/100ms
Accuracy	0.01%rdg+2d (+4d current operated mode)
Contact o/c	24V
Contact s/c	20mA
VDC	24—240V

Each contact circuit will auto-select for normally open or normally closed contacts. A DC voltage of 24—240VDC may also be used to trigger either timer channel. Contact state is shown by an LED. The output automatically switches off at the end of the test to safeguard the relay under test.

Mode	Timer Start	Timer Stop
Internal start	Press 'ON'	C1 or C2 change
1 contact	C1 1st change	C1 2nd change
2 contacts	C1 change	C2 change
Current operated	Current > 10% of metering range	Current < 10% of metering range
Pulse	Press 'ON'	200ms

Pulse mode is used for setting the current level in devices sensitive to heating. Current is injected for 200ms.

Supply Requirements

115/230V±10% auto-selecting 50/60Hz 1ph 1200VA.

RS232 and T&R Link

An RS232 port is provided to allow connection to a PC or a printer. The T&R Link output allows a T&R DVS3 mk2 voltage source to phase lock to the 100ADM mk5 current.

Protection and Safety

The unit is designed to comply with BSEN61010 and is CE marked. An earth terminal is provided for connection to a local earth for testing in sub-station environments.

Dimensions

Peli case:	560 x 456 x 265mm	Weight 23.9kg
Metal case:	390 x 315 x 225mm	20kg

Temperature Range

Storage	-20°C to 60°C	Operating	0°C to 45°C
---------	---------------	-----------	-------------

Lead Set specifications

The 100ADM mk5 is supplied with a lead set consisting of:

- 2 x 5m 25mm² 100A leads terminated in M10 fork crimps
- 2 x 5m, 2 x 0.5m 2.5mm² 25A leads with in 4mm plugs
- 1 x 5m 2 core 0.75mm² lead terminated in 4mm plugs

Accessories

Operating manual, output lead set, mains lead and spare fuses.

Optional Accessories

100ADM-F Filter unit, RB10 resistor box, printer, pushbutton lead for runback timing on disc induction relays.

100A/E mk3

Current Injection System



Features

- Wide range of output currents
- AC and DC voltage outputs
- All outputs continuously variable
- Output current metering 40mA-200A
- Automatic switch-off in all modes of operation
- Multi-function timing system
- Suitable for testing thermal devices
- Compact and highly portable
- Voltage and current outputs available simultaneously

T&R Test Equipment is a market leader in the field of current injection equipment. The range includes secondary injection units with 100A output capability up to 6000A primary injection systems. All have true RMS metering, a flexible timing system, and an easy to understand user interface.

The 100A/E mk3 secondary current injection test set has been designed to give the maintenance and commissioning engineer a large number of facilities in one self-contained instrument.

The unit is portable, compact and simple to use. The mains supply for the unit is either 240V \pm 10% or 115V +10% -6% at either 50 or 60Hz. Full load can be obtained at the supply voltage extremes.

The current and voltage outputs are independently controlled and metered. The output current and voltage are displayed on large, clear panel instruments. An additional four range CT is provided, extending the ammeter range down to 0-100mA.

All of the outputs are fully isolated by means of double wound transformers.

The timing system on the 100A/E is very flexible, without compromising ease of use. Four modes of operation and two contact inputs are provided allowing for a wide range of events to be timed. Both contact inputs automatically select for normally open or normally closed contacts. Operation of the different timing modes is described overleaf.

Internal start mode starts the timer when the 'ON' pushbutton is pressed, and stops the timer when the first contact set changes state. This mode is ideally suited to timing over-current relays.

Single contact mode starts and stops the timer on the first and second changes of state of the first contact set, and dual contact mode starts the timer from the first set of contacts and stops it from the second set. These modes allow reset and re-close times of protective devices to be easily measured.

The final mode of operation of the timer starts the timer when the current exceeds 20% of the selected metering range, and stops it when the current falls below 20%. This allows the timing of trips with no auxiliary contacts such as miniature circuit breakers.

Automatic control has been provided such that all outputs can be switched off once the device under test has operated. The automatic control can be switched in or out of circuit for all outputs, enabling setting up procedures to be carried out.

The instrument is housed in a robust case complete with a protective cover and fold-away carrying handles.

100A/E Mk3 Specification

Current Output

The current output on the unit has eight ranges, allowing the selection of output voltages up to 150V and output currents up to 200A. The current outputs

Range	Continuous	5 minutes	1 minute	VAC
200A	50A	100A	200A	0-5V
100A		100A	-	0-5V
50A	25A	50A	-	0-10V
25A	12.5A	25A	-	0-20V
10A	5.0A	10A	-	0-50V
5.0A	2.5A	5.0A	-	0-50V
2.5A	1.25A	2.5A	-	0-50V
1.0A	0.5A	1.0A	-	0-150V

may also be used as voltage outputs.

The above intermittent ON times must be followed by an OFF time of 15 minutes, and are based on an ambient temperature of 25°C.

Voltage Output

The voltage output on the unit has three ranges,

Voltage	Output current	
	Continuous	5 minutes
0-250Vac	0.5A	1.0A
0-500Vac	0.25A	0.5A
0-250Vdc	0.5A	1.0A

allowing the selection of output voltages up to 500Vac and 250VDC.

The above intermittent ON times must be followed by an OFF time of 15 minutes, and are based on an ambient temperature of 25°C.

Metering

The output is a true RMS analogue system with separate instruments for current and voltage.

AC current is metered by a dual scaled ammeter reading 0-1A and 0-5A. The following scaling factors are used:

Range	1A Scale	5A Scale	Accuracy
0.1A	x0.1	x0.02	Class 1.5
0.25A	x0.25	x0.05	Class 1.5
0.5A	x0.5	x0.1	Class 1.5
1.0A	x1	x0.2	Class 1.5
2.5A	x2.5	x0.5	Class 1.5
5.0A	x5	x1	Class 1.5
10A	x10	x2	Class 1.5
25A	x25	x5	Class 1.5
50A	x50	x10	Class 1.5
100A	x100	x20	Class 1.5
200A	x200	x40	Class 1.5

AC voltage is metered by a dual scaled ammeter reading 0-300V and 0-600V. The following scaling factors are used:

Range	300V Scale	600V Scale	Accuracy
300V	x1	x0.5	Class 1.5
600V	x2	x1	Class 1.5

Timing System

Range 0-999.999s

Resolution 1ms

Accuracy $\pm 0.1\%$ rdg $\pm 2d$ (all modes, not current)

Accuracy $\pm 0.1\%$ rdg $\pm 3d$ (current operated mode)

The contact circuit has an open circuit voltage of 24VDC and a short circuit current of 100mA. Each contact circuit will auto-select for normally open or normally closed contacts. A DC voltage of 24-240VDC may also be used to trigger either timer channel.

The following functions are provided:

Mode	Timer Start	Timer Stop
Internal start	Press 'ON'	Contact 1
Single contact	Contact 1	Contact 1
Dual contact	Contact 1	Contact 2
Current operated	Current > 20% of range	Current < 20% of range

The output may be automatically switched off at the end of the test to safeguard the relay under test. This is selectable for both the voltage and current output.

Protection and Safety

The unit is protected by the following fuses:

Input supply	T5A 240V supply T10A 115V supply
Output supplies	T3.15A
Contacts	F0.25A
Aux CT circuit	T315mA and T1.25A

An earth terminal is provided for connection to a local earth.

Supply Requirements

115V $\pm 10\%$ -6% 50/60Hz 1ph 1450VA max
240V $\pm 10\%$ 50/60Hz 1ph 1450VA max

Temperature Range

Storage -20°C to 60°C **Operating** 0°C to 45°C

Dimensions

490 x 300 x 300mm

Weight

33kg

Accessories

Operating manual, 2m mains lead, 100AL lead set
Non-latching contact lead, Spare fuse set

Optional Accessories

100ADM-F 100A Waveform Filter unit

100ADM-F

Current Filter Unit



The 100ADM-F filter unit reduces the level of current harmonics when testing electro-mechanical protection relays. It is designed for use with our range of secondary injection test sets.

All electromechanical protection relays have iron cores that saturate and distort the test current under high overload test conditions. This distortion causes significant errors in the measured trip time of these relays during testing. Distortion of the waveform can be a particular problem with disc induction type over-current and sensitive earth fault relays.

For example, testing a CDG11 disc induction over-current relay without a filter causes significant timing errors. The results below show the errors for

	Current	THD	Trip time	Error
No Filter	5A	34.5%	1.54s	18.5%
With Filter	5A	6.12%	1.30s	0%

a 1.3s 1A CDG11 over-current relay on its 0.5A plug setting, tested at 5A.

The 100ADM-F has nine current ranges covering 0.25A to 100A and is supplied in an insulated case complete with protective cover and carrying strap.

Accessories

Current monitor plug and lead

Optional Accessories

100AL lead set

Temperature Range

Storage -20°C to 60°C Operating 0°C to 45°C

Dimensions

340 x 230 x 330mm

Weight

15.6kg

Frequency

The unit may be used at either 50Hz or 60Hz, selectable by a switch on the front panel.

Current Monitor

A current monitoring output is provided that gives an output of 0-100mA corresponding to the rated current for the range.

Features

- Forces test current to a sinusoid
- Improves timing accuracy when testing electromechanical relays
- 0.25A-100A ranges
- High overload capability
- 50/60Hz operating frequency
- High efficiency

100ADM-F Specification

Current Waveforms

The waveforms below show the current and voltage for a disc induction relay supplied from a 100ADM.

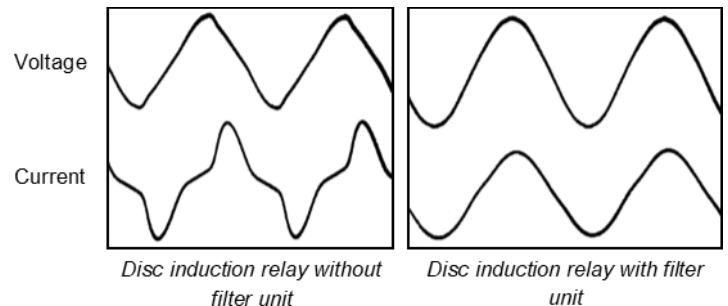

Current Ranges and Ratings

Range	Continuous rating 5 min on/15 min off	
0.25A	0.125A	0.25A
0.5A	0.25A	0.5A
1A	0.5A	1A
2.5A	1.25A	2.5A
5A	2.5A	5A
10A	5A	10A
25A	12.5A	25A
50A	25A	50A
100A	50A	100A

Range Selection

The lower ranges (0.25A-50A) are selected by a switch, and the highest current range (100A) is selected by a terminal.

Filter Unit Impedance

Range	Impedance (Ω)			
	50Hz	150Hz	250Hz	350Hz
0.25A	880Ω	17.5kΩ	30.4kΩ	41.5kΩ
0.5A	220Ω	4.38kΩ	7.65kΩ	10.3kΩ
1A	47.7Ω	950Ω	1.65kΩ	2.25kΩ
2.5A	7.8Ω	150Ω	250Ω	360Ω
5A	1.94Ω	38Ω	65Ω	90Ω
10A	510mΩ	9.5Ω	16.5Ω	22.5Ω
25A	85mΩ	1.5Ω	2.5Ω	3.6Ω
50A	22mΩ	380mΩ	650mΩ	900mΩ
100A	5.5mΩ	95mΩ	165mΩ	225mΩ

RB10

Resistor Box



The RB10 resistor box is used in conjunction with a current injection unit when testing low impedance relays and trips, allowing finer control of the current. The unit is designed for use with the 100ADM and 200ADM-P, but may be used with any suitable current source.

The unit has eight resistance ranges with a maximum power dissipation of 50W for any one resistor.

The RB10 is supplied in a robust aluminium case, and all connections are made by industry standard 4mm safety sockets.

Protection

The unit has over-temperature protection and the common terminal is fused with a T10A fuse.

Range Selection

The appropriate range is selected by 4mm safety sockets on the front panel of the unit.

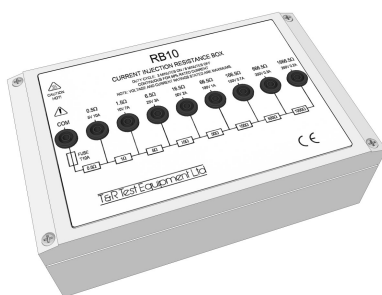

Features

- Improves current control into low impedance loads
- Particularly suitable for solid state relays
- 0.5W—1666.5W in 8 steps
- Maximum current 0.2—10A
- Thermal cutout
- Compact & lightweight

RB10 Specification

Resistance Ranges and Ratings

The RB10 has eight resistance ranges:

Range	Continuous	Intermittent	Maximum
0.5W	5A	10A	5V
1.5W	3.5A	7A	10V
6.5W	1.5A	3A	25V
16.5W	1A	2A	50V
66.5W	0.5A	1A	100V
166.5W	0.35A	0.7A	150V
666.5W	0.15A	0.3A	250V
1666.5W	0.1A	0.2A	250V

*3 minutes on/8 minutes off

Temperature Range

Storage -20°C to 60°C

Operating 0°C to 45°C

Dimensions

220 x 163 x 72mm
including earth terminal

Weight

2Kg

Optional Accessories

S000-0534 5m low current lead set

50A-3PH_{mk2}

3 Phase Current Injection System



Features

- Clear and simple user interface
- 3 phase current output
- 0-50A per phase output current
- True RMS digital metering
- Memory ammeter
- Multi-function timing system
- Auxiliary metering input
- Large back-lit liquid crystal display
- Thermal and over-current protection
- Compact and portable
- 220V 3 Φ or 400V 3 Φ supply options*
- 115V-440V 3 wire supply with optional supply transformer

*See supply requirements overleaf

T&R Test Equipment is a market leader in the field of current injection equipment. The range includes secondary injection units with 50A output capability up to 6000A primary injection systems. All have true RMS metering, a flexible timing system, and an easy to understand user interface.

The 50A-3PH mk2 is a three phase injection system providing commissioning and maintenance engineers with a flexible system for testing protective systems. It has an easy to understand panel layout and a simple user interface. The status of every function can be seen at a glance, and there are no complex menus to navigate.

The unit has a range of outputs allowing injection of currents as low as a few mA and as high as 50A. Voltages up to 18V are available on the main outputs. Three true RMS metering ranges are provided, allowing the full scale of the meter and trip level to be set independently of the selected output. Industry standard safety connectors are used on all inputs and outputs for convenience, reliability and safety.

The 50A-3PH mk2 is protected by electronic over current and duty cycle trips on the outputs, thermal monitoring on the power components, and fuses on the input and regulator. An earth terminal is provided for connection to a local earth.

The unit is designed to comply with BSEN61010, and is CE marked.

An auxiliary metering input is provided and can measure voltage, current, frequency, and the phase between any of the current outputs and an external voltage or current.

The timing system is very flexible without compromising ease of use, allowing trip times, reset times and reclose times to be quickly measured to a high degree of accuracy. Two independently isolated contact inputs are provided, and the timing system may also be used as a stand-alone timer.

The 50A-3PH mk2 can be used to test many types of single and three phase secondary protection including:

- Over and under current relays
- Power relays
- IDMT relays
- Tripping relays
- Auto-reclosers
- Thermal relays
- Time delay relays
- Miniature circuit breakers
- Earth fault relays



The back-lit display on the 50A-3PH mk2 is bright and clear with a wide viewing angle. The results of a test can be seen here as they appear on the display.

50A-3PH mk2 Specification

Main Output

The main output on the unit has two taps, allowing the selection of output voltages up to 18V and output currents up to 50A.

Range	Continuous	5 minutes	1 minute
3.5V	16A	32A	50A
18V	4A	8A	12A

The above intermittent on times must be followed by an off time of 15 minutes, based on an ambient temperature of 25°C.

Metering

The output is metered by a digital true RMS system with a memory ammeter - whenever the timer stops and the output is switched off, the current reading is held on the display. The currents for each phase are displayed simultaneously.

Range	Resolution	Trip current	Accuracy
5.000A	0.001A	5.25A	$\pm 0.6\%rdg+5d$
20.00A	0.01A	21A	$\pm 0.6\%rdg+5d$
50.00A	0.01A	52.5A	$\pm 0.6\%rdg+5d$

A current trip is automatically set to 105% of full scale of the current metering range to protect the device under test.

Auxiliary Metering Inputs

An auxiliary metering input is provided which is able to measure RMS voltage or current. In addition the frequency of the external input may be measured, and the phase measured between any of the phase outputs and the auxiliary metering input.

Setting	Range	Resolution	Accuracy
Volts AC	270.0V	0.1V	$\pm 0.7\%rdg+5d$
Volts AC	270.0V	0.1V	$\pm 0.7\%rdg+5d$
Amps AC	5.000A	1mA	$\pm 0.7\%rdg+5d$
Phase	$\pm 180^\circ$	0.1°	$\pm 3^\circ$
Frequency	20-1000Hz	0.1Hz	$\pm 0.2\%rdg+1d$

The current input is protected by a F6.3A fuse.

Auxiliary Output

A single phase isolated 110Vac 300mA/220Vac 150mA auxiliary output is provided.

Lead Set Specifications

The 50A-3PH is supplied with a lead set including:

6 x 3m 4mm² output leads with 4mm plugs

2x3m 2x0.5m 2.5mm² auxiliary leads with 4mm plugs

RS232 and T&R Link

An RS232 port is provided to allow connection of a printer or PC and the T&R link output provides a phase lock reference.

Dimensions

Peli case: 560 x 456 x 265mm

Metal case: 380 x 314 x 221mm

Weight

24.9kg

21kg

Supply Requirements

The supply voltage requirements for the unit must be specified at the time of ordering. The unit is available for operation from either a 400V 4 wire 3 ϕ supply or 220V 3 wire 3 ϕ supply. The optional delta-star supply transformer allows the 400V unit to operate from other supply voltages.

Option 1: 400V-10%+14% 50/60Hz 3ph 1kVA

Option 2: 220V-6%+14% 50/60Hz 3ph 1kVA

Timing System

Range 0-999.999s **Resolution** 1ms
Accuracy 0.01%rdg+2d (+4d current operated mode)

The contact circuit has an open circuit voltage of 24VDC and a short circuit current of 20mA. Each contact circuit will auto-select for normally open or normally closed contacts. A DC voltage of 24-240VDC may also be used to trigger either timer channel. The output is automatically switched off at the end of the test to safeguard the relay under test.

The following functions are provided:

Mode	Timer Start	Timer Stop
Internal start	Press 'ON'	Contact 1
Single contact	Contact 1	Contact 1
Dual contact	Contact 1	Contact 2
Current operated	Current > 10% of range	Current < 10% of range

Pulse mode is used for setting the current level in devices sensitive to heating, and allows current to be injected for 500ms, and the current recorded.

Current operated mode operates on one output phase (selectable).

Temperature Range

Storage -20°C to 60°C **Operating** 0°C to 45°C

Accessories

Operating manual, output lead set, mains lead, spare fuse set.

Optional Accessories

Delta-Star supply transformer, filter unit, printer, leadset carry case.

Optional Delta-Star Supply Transformer

The optional delta-star supply transformer allows operation from 115V, 230V, 400V, and 440V 3 wire supplies, selected by a switch on the unit. An auxiliary single phase output is also provided to supply power to a DVS3 voltage source.

Input: 115V, 230V, 400V, 440V $\pm 10\%$
3 wire 3 phase 1500VA max

3 ϕ output: 400V 4 wire 600VA
 1 min on/15 min off

1 ϕ output: 230V 300VA
 5 min on/15 min off



200A-3PH_{mk3}

3 Phase Current Injection System



Features

- 3 phase current output
- 0-200A per phase output current
- True RMS digital metering
- Memory ammeter
- Multi-function timing system
- Auxiliary metering input
- Large back-lit liquid crystal display
- Thermal and over-current protection
- Compact and portable
- 400V 3 Φ supply*
- 115V-440V 3 wire supply with optional supply transformer

*See supply requirements overleaf

T&R Test Equipment is a market leader in the field of current injection equipment. The range includes secondary injection units with 50A output capability up to 6000A primary injection systems. All have true RMS metering, a flexible timing system, and an easy to understand user interface.

The 200A-3PH mk3 is a three phase injection system providing commissioning and maintenance engineers with a flexible test set for testing protective systems. It has an easy to understand panel layout and a simple user interface. The status of every function can be seen at a glance, and there are no complex menus to navigate.

The outputs are isolated and independently variable, allowing injection of currents up to 200A. Voltages up to 5V are also available on the main outputs. Four true RMS metering ranges are provided, allowing the full scale of the meter and trip level to be set independently of the selected output. Industry standard safety connectors are used on all inputs and outputs for convenience, reliability and safety.

The 200A-3PH mk3 is protected by electronic over current and duty cycle trips on the outputs, thermal monitoring on the power components, and fuses on the input and regulator. An earth terminal is provided for connection to a local earth. The unit is designed to comply with BSEN61010, and is CE marked.

An auxiliary metering input is provided and can measure voltage, current, frequency, and the phase between any of the current outputs and an external voltage or current.

The timing system is very flexible without compromising ease of use, allowing trip times, reset times and reclose times to be quickly measured to a high degree of accuracy. Two independently isolated contact inputs are provided, and the timing system may also be used as a stand-alone timer.

The 200A-3PH mk3 can be used to test many types of single and three phase secondary protection including:

- Over and under current relays
- Power relays
- IDMT relays
- Tripping relays
- Auto-reclosers
- Thermal relays
- Time delay relays
- Miniature circuit breakers
- Earth fault relays



The back-lit display on the 200A-3PH mk3 is bright and clear with a wide viewing angle. The results of a test can be seen here as they appear on the display.



200A Delta-Star Unit

200A-3PH mk3 Specification

Main Output

The test set has three independently controlled outputs, one for each phase, allowing the selection of output voltages up to 5V and currents up to 200A.

Range	Continuous	5 minutes	1 minute
0-5V	50A	100A	200A

The above intermittent on times must be followed by an off time of 15 minutes, and are based on an ambient temperature of 25°C.

Metering

The output is metered by a digital true RMS system with a memory ammeter - whenever the timer stops and the output is switched off, the current reading is held on the display. The currents for each phase are displayed simultaneously. The current trip is set to 105% of full scale of the metering range to protect the device under test.

Auxiliary Metering Inputs

Range	Resolution	Trip current	Accuracy
20.00A	0.01A	21.0A	±0.6%rdg+5d
50.00A	0.01A	52.5A	±0.6%rdg+5d
100.00A	0.1A	105.0A	±0.6%rdg+5d
200.00A	0.1A	210.0A	±0.6%rdg+5d

An auxiliary metering input is provided which is able to measure RMS voltage or current. In addition the frequency of the external input may be measured, and the phase measured between any of the phase outputs and the auxiliary metering input.

The current input is protected by an F10A fuse.

Setting	Range	Resolution	Accuracy
Volts AC	300.0V	0.1V	±0.7%rdg+5d
Amps AC	10.000A	1mA	±0.7%rdg+5d
Phase	±180°	0.1°	±3°
Frequency	40-100Hz	0.01Hz	±0.2%rdg

Auxiliary Output

A single phase isolated 110Vac 300mA auxiliary output is provided on the 200A-3PH mk3.

Lead Set Specifications

The 200A-3PH mk3 is supplied with a lead set in a plastic case including:

- 6 x 5m 25mm² output leads terminated in M10 fork crimps
- 1 x 5m 2 core auxiliary timer lead terminated in 4mm plugs

Supply Requirements

The unit must be supplied by a 400V±10% 50/60Hz 3 phase 3300VA Max. The optional delta-star supply transformer allows the 400V unit to operate from other supply voltages.

Temperature Range

Storage -20°C to 60°C **Operating** 0°C to 45°C

RS232 and T&R Link

An RS232 port is provided to allow connection of a printer or PC and the T&R link output provides a phase lock reference for a DVS3 mk2 phase-shifting voltage source.

USB data storage

All test results from the 200A-3PH mk3 can be stored to a USB memory key. All results are time and date-stamped and can include a user defined comment. All saved results can be viewed on the control unit display or on a PC.

Timing System

Range	0-999.999s	Resolution	1ms
Accuracy	0.01%rdg+2d (+4d current operated mode)		

The contact circuit has an open circuit voltage of 24VDC and a short circuit current of 20mA. Each contact circuit will auto-select for normally open or normally closed contacts. A DC voltage of 24-240VDC may also be used to trigger either timer channel. The output is automatically switched off at the end of the test to safeguard the relay under test.

The following functions are provided:

Mode	Timer Start	Timer Stop
Internal start	Press 'ON'	Contact 1
Single contact	Contact 1	Contact 1
Dual contact	Contact 1	Contact 2
Current operated	Current > 20% of range	Current < 20% of range

Pulse mode is used for setting the current level in devices sensitive to heating, and allows current to be injected for 500ms and the current recorded.

Current operated mode operates on one output phase (selectable).

Accessories

Operating manual, output lead set, mains lead, spare fuse set, USB memory key, and USB keyboard.

Optional Accessories

Delta-Star supply transformer, printer, T&R Link lead.

Dimensions

315 x 550 x 300mm
Including handle and corner protectors

Weight

33kg

Optional Delta-Star Supply Transformer

The optional delta-star supply transformer allows operation from 115V, 230V, 400V, and 440V 3 wire supplies, selected by a switch on the unit. An auxiliary single phase output is also provided to supply power to a DVS3 mk2 voltage source.

Input: 115V, 230V, 400V, 440V ±10%
3 wire 3 phase 1500VA max

3Φ output: 400V 4 wire 600VA
1 min on/15 min off

1Φ output: 230V 300VA
5 min on/15 min off

1200A-3PH

3 Phase Current Injection

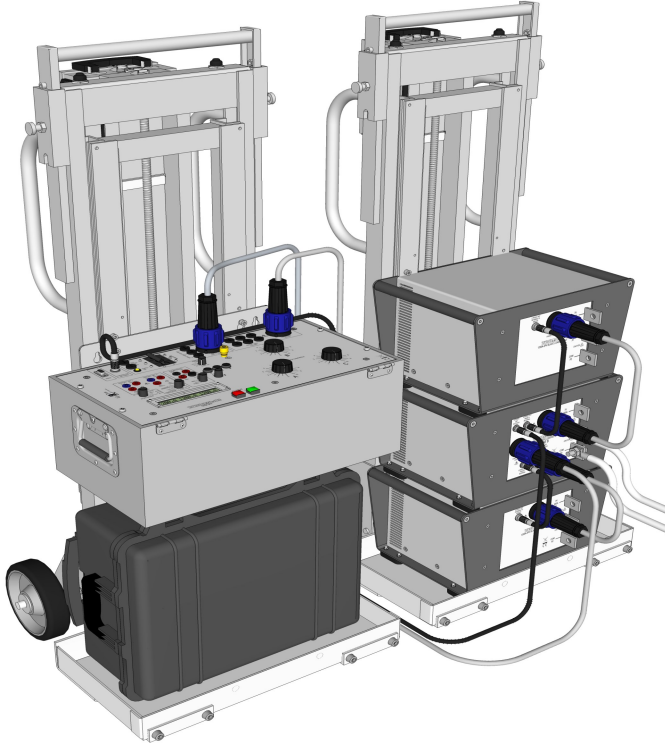

Features

- Clear and simple user interface
- 3- Φ current output
- 0-1200A per phase output current
- True RMS digital metering
- Memory ammeter
- Multi-function timing system
- Auxiliary metering input
- Large back-lit liquid crystal display
- Thermal and over-current protection
- Portable on battery powered stair climbing trolleys
- Maximum power output 13kVA

The 1200A-3PH is a three phase injection system providing commissioning and maintenance engineers with a flexible system for testing protective systems. It has an easy to understand panel layout and a simple user interface. The status of every function can be seen at a glance, and there are no complex menus to navigate.

Each loading unit has two output taps to allow for a range of load impedance. Each phase is isolated and can be configured to either give a maximum of 1200A at 3.5V or 600A at 7V. Three true RMS metering ranges are provided, allowing the full scale of the meter and trip level to be set independently of the selected output.

An auxiliary metering input is provided and can measure voltage, current, frequency, and the phase between any of the current outputs and an external voltage or current.

The timing system is very flexible without compromising ease of use, allowing trip times, reset times and reclose times to be quickly measured to a high degree of accuracy. Two independently isolated contact inputs are provided, and the timing system may also be used as a stand-alone timer.

The 1200A-3PH can be used to test many single and three phase devices including:

- Over current relays
- Under current relays
- IDMT relays
- Auto-reclosers
- Time delay relays
- Earth fault relays
- Miniature circuit breakers
- Power relays
- Tripping relays
- Thermal relays

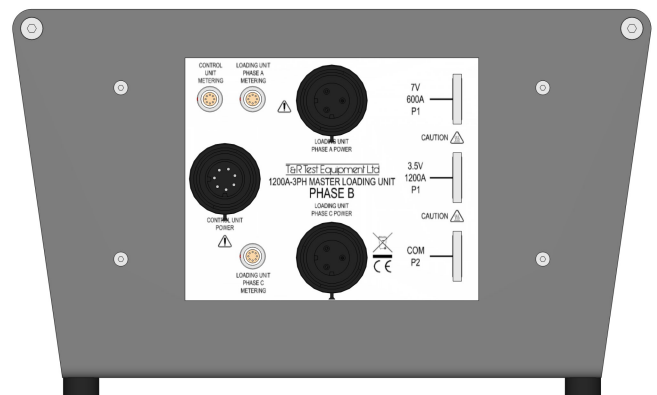
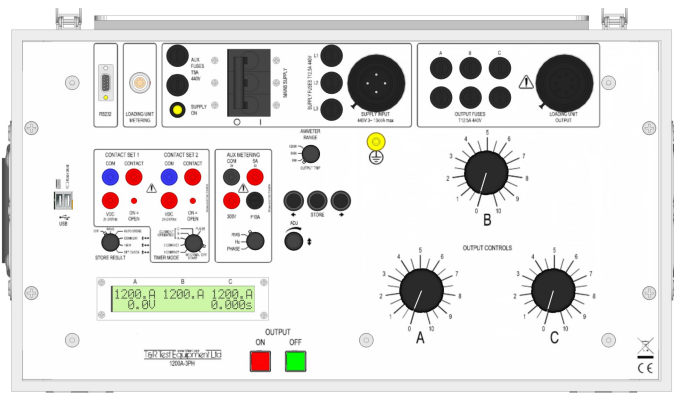

1200A-3PH Specification

Loading Unit Ratings

The AC Output current is metered by a true RMS memory ammeter (acquisition time 200ms) with an LCD display. The current metering has 3 ranges 60A, 500A and 1200A. The main output on the loading unit has two taps, allowing the selection of output voltages up to 7V and output currents up to 1200A.

Range	Continuous	5 minutes	1 minute	20s
3.5V	350A	600A	1000A	1200A
7V	175A	300A	500A	600A

The above intermittent on times must be followed by an off time of 15 minutes, and are based on an ambient temperature of 25°C.

Metering

The output is metered by a digital true RMS system with a memory ammeter - whenever the timer stops and the output is switched off, the current reading is held on the display. The currents for each phase are displayed simultaneously.

Range	Resolution	Trip current	Accuracy
60.00A	0.01A	63A	±0.6%rdg+5d
500.0A	0.1A	525A	±0.6%rdg+5d
1200A1A		1260A	±0.6%rdg+5d

A current trip is automatically set to 105% of full scale of the current metering range to protect the device under test.

USB Storage of Results

All test results from the 1200A-3PH can be stored to a USB memory key. All results are time and date-stamped, and can include a user defined comment. All saved results can be viewed on the control unit display or on a PC.

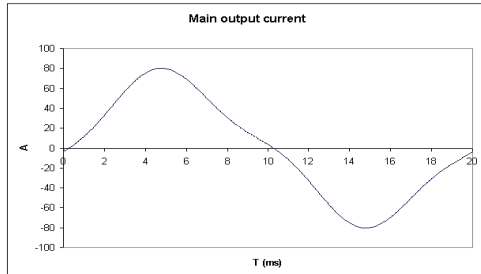

In addition to this the 1200A-3PH can store a .BMP file of the waveform to the USB key.

Auxiliary Metering Inputs

An auxiliary metering input is provided which is able to measure RMS voltage or current. In addition the frequency of the external input may be measured, and the phase measured between any of the phase outputs and the auxiliary metering input.

Setting	Range	Resolution	Accuracy
Volts AC	270.0V	0.1V	±0.7%rdg+5d
Amps AC	5.000A	1mA	±0.7%rdg+5d
Phase	±180°	0.1°	±3°
Frequency	20-1000Hz	0.1Hz	±0.2%rdg+1d

The current input is protected by a F6.3A fuse.

Supply Requirements

440V±10% 50/60Hz 3ph (3P+E) 1300VA

RS232

An RS232 port is provided to allow connection to a printer or PC.

Timing System

Range	0-999.999s	Resolution	1ms
Accuracy	0.01%rdg+2d (+4d current operated mode)		

The contact circuit has an open circuit voltage of 24VDC and a short circuit current of 20mA. Each contact circuit will auto-select for normally open or normally closed contacts. A DC voltage of 24-240VDC may also be used to trigger either timer channel. The output is automatically switched off at the end of the test to safeguard the relay under test.

The following functions are provided:

Mode	Timer Start	Timer Stop
Internal start	Press 'ON'	Contact 1
Single contact	Contact 1	Contact 1
Dual contact	Contact 1	Contact 2
Current operated	Current > 10% of range	Current < 10% of range

Pulse mode is used for setting the current level in devices sensitive to heating, and allows current to be injected for 200ms and the current recorded.

Current operated mode operates on one output phase (selectable).

Protection and Safety

The unit is protected by electronic over current and duty cycle trips on the outputs, thermal monitoring on the power components, and fuses on the input and regulator. An earth terminal is provided for connection to a local earth. The unit is designed to comply with BSEN61010 and is CE marked.

Lead Set Specifications

The 1200A-3PH is supplied with a lead set in a plastic case including:

- 1 x 5m mains lead
- 1 x 5m power interconnection lead: control unit to master loading unit
- 2 x 1m power interconnecting leads: master to slave loading units
- 1 x 5m metering interconnect lead: control unit to master loading unit
- 2 x 1m metering interconnecting leads: master to slave loading units
- 6 x 3m 95mm² output leads terminated in M12 Crimps
- 1 x 5m 2 core timer lead terminated in 4mm plugs

*Additional leads can be supplied

Temperature Range

Storage -20°C to 60°C **Operating** 0°C to 45°C

Dimensions

	Dimensions	Weight
Loading unit	450 x 275 x 370mm	44kg
Control Unit	315 x 550 x 300mm	35kg
Trolley	610 x 450 x 1450mm	

Accessories

Operating manual, spare fuse set, USB memory key, USB keyboard, lead set case. 2 battery operated stair climbing trolleys with spare batteries and chargers.

ART3V

Relay Test System



The new ART3V brings new features to our range of relay test equipment making it far more adaptable. The new output voltages are higher and have a finer level of accuracy and control. The new full colour LCD provides more test detail, making it easy to understand. The ART3V user interface is an improvement of the DVS3 mk2 allowing simple testing of complex voltage and loss of mains protection systems.

The display on the ART3V is back-lit and exceptionally clear. Menu options on the bottom are selected by dedicated buttons on the panel below the display, allowing immediate access to adjust voltage, phase and frequency. Phase to phase and phase to neutral voltages are both shown on the display, along with frequency and phase information. A graphical vector diagram is shown, as is the state of the two contact inputs.

The ART3V has vastly improved accuracy, stability, and features. Designed to be the trusted and reliable voltage source for relay testing. The ART3V has been designed using the latest digital technology to generate a highly stable and accurate output with very low distortion. Each phase output is individually adjustable for voltage, frequency and phase angle. The unit is controlled by a simple user interface within defined menus. Values may be either typed in at the capacitive keypad or finely varied using a smooth rotary encoder.

Bespoke test procedures can be created for step changes of any output variable at set times or with automatic timing of the response of the relay under test.

Features

- 3- ϕ Voltage output from 1- ϕ supply
- 0-450V ϕ -N output voltage
- 20VA/phase maximum output
- Variable Frequency 30-999.9Hz
- Phase shift $\pm 180.0^\circ$
- Multi-function timing system
- USB keyboard for comment
- USB Data Storage
- Ideally suited to testing G59 schemes
- Step change of phase and df/dt
- 6.5" back-lit colour LCD
- Automatic mains voltage selection
- Fully Programmable test procedures
- Rugged case, weighs under 9kg

The ART3V is ideally suited to testing G59 protection, including loss of mains protection. Vector surge and df/dt (ROCOF) relays can be simply tested and timed, as well as other protection requiring one to three voltages, including:

- Under and over frequency relays
- Under and over voltage relay
- Synchronising relays
- df/dt & ROCOF relays
- Vector surge relays
- Transducers

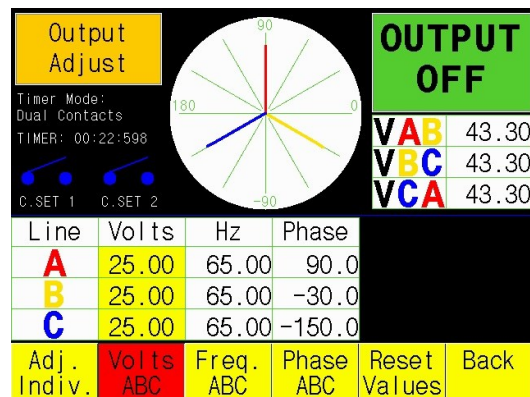

In conjunction with a current source (such as the 200ADM-P), the ART3V can be used to test protection circuits requiring current injection with a phase-shiftable voltage including:

- Directional relays
- Distance protection
- Power transducers

Accessories

Output lead set, carry case, mains lead, spare fuses, operating manual, USB memory key & keyboard.

ART3V Specification

Output

The output of the ART3V has 4mm safety sockets for phases A, B, C and neutral. The neutral connection may be omitted for a delta connection. The neutrals can be linked for a star connection using the provided accessory.

Voltage	0-450Vac phase-neutral
Current (continuous)	40mA at 450V
Voltage resolution	0.01V phase-neutral
Phase rotation	±180.0°
Voltage accuracy	±0.1%rdg+2d

*All output ratings are based on ambient temperature of 25°C.

Timing System

The timing system on the ART3V is flexible and transparent with different modes of operation. In INTERNAL START mode step changes of any quantity automatically resets and starts the timer when the change is applied. The timer then stops on a change of state of either contact set input. Contacts can be used to trigger the timer based on external relay changes. Also, more complex timing functions are handled by the Fault Config mode.

Two contact inputs are provided, both of which have LEDs and a mimic on the display to show the contact state. The contact inputs auto-select for normally open or normally closed contacts. A DC voltage can also be used to trigger the timer using the Vdc contact.

Timer resolution	1/10/100ms
Timer full scale	0-999.999/9999.99s/99999.9s
Timer accuracy	±0.01%rdg+2d
Contact O/C voltage	24V
Contact S/C current	20mA
VDC input range	24-240VDC

Protection and Safety

The ART3V is CE marked and is designed to meet the requirements of BS EN61010, and EMC tested to BS EN 61326. The outputs are protected by overcurrent and thermal trips, and the contact inputs are protected by PTC thermistors. The phase lock current input is fuse protected, and the voltage input is impedance protected. An earth terminal is provided for connection to a local earth.

Supply Requirements

90V-264V 45-65Hz 1ph 300VA max

Temperature Range

Storage -20°C to 60°C Operating 0°C to 45°C

Lead Set Specifications

1 x 3m 4 core output lead terminated in 4mm plugs
1 x 3m 2 core timer lead terminated in 4mm plugs

Dimensions

419 x 325 x 195mm

Weight

8.9kg

Modes of Operation

Output Adjust

This mode allows full control of frequency, voltage and phase. Each voltage and phase can be controlled together or independently. All parameters are continuously variable using the adjust control, and step changes of any value. The timer automatically resets and starts when a step change of value is entered, and stops if either contact input changes state. Step changes of phase for testing Vector Surge relays are easily generated in this mode.

Frequency resolution	0.01Hz 0.1Hz	40.00-99.99Hz 100.0-999.9Hz
Frequency accuracy		±0.05%rdg+2d
Phase resolution		0.1°
Phase accuracy		±0.3° phase to phase

Phase Lock Mode

The frequency and phase of the output are controlled by an external reference in phase lock mode. The reference may be the mains supply or an external voltage or current. This mode allows testing of directional and distance protection in conjunction with an external current source.

Phase lock range	45-65Hz
External voltage ref.	20-250Vac
External current ref.	0.2-5Aac
Phase resolution	0.1°
Phase accuracy	±0.3° phase to phase ±3.0° reference to output

df/dt and ROCOF (Rate Of Change Of Frequency)

Loss of mains protection often takes the form of a df/dt relay, sensitive to the rate of change of frequency over time. The ART3V is able to generate a swept frequency output with accurate rates of change of frequency between preset frequencies. The rate of change may be continuously varied to find the relay setting or stepped to time the relay. The output may be set to either sweep continuously or generate single sweeps with timing.

Frequency range	30.00-999.99Hz
Frequency resolution	0.01Hz
Rate of Change range	0.001-9.001Hz/s

Fault Config Mode

Fault Config mode allows extra flexibility in testing complex timed events or several sets of values must be applied to a relay in turn. This mode allows three sets of values to be set in advance (pre-fault, fault, and post-fault values). The ART3V may be set to switch from one state to the next on a change of contact or after a specific time. In addition, the timer may be set to start or stop on any one of the state changes of a change of contact state. This mode allows frequency, phase and voltage to be changed simultaneously if required. More complex test configurations can be loaded from and saved to the USB, such as a complete G59 relay test, E.g. relay stability tests.

750ADM-H_{mk3}

Current Injection System



Features

- Primary injection up to 750A
- 4V output*
- 16V 40A output for secondary injection
- True RMS memory ammeter with single cycle capture
- Multi-function timing system
- Large back-lit liquid crystal display
- Thermal and over-current protection
- Automatic switch-off at end of test
- Compact and portable
- Automatic mains voltage selection*

*See specifications overleaf

T&R Test Equipment is a market leader in the field of current injection equipment. The range includes secondary injection units with 100A output capability up to 6000A primary injection systems. All have true RMS metering, a flexible timing system, and an easy to understand user interface.

The 750ADM-H mk3 is a compact, rugged primary current injection system with a 750A output capability. The 750ADM-H mk3 has a maximum no load output voltage of 5V. The unit is ideally suited to all low power primary injection tasks requiring up to 750A for short periods.

Unit type	Max. power	Max. current
750ADM-H	3kVA	750A
PCU1-SP + NLU5000	11.5kVA	3kA 5min/5kA 40s
CU-PS + PLU6000	20kVA	6kA

Where higher currents and powers are required for primary injection, 11kVA and 20kVA primary injection systems are also available.

The PCU1-SP and CU-PS systems have separate control units, allowing a wide range of load conditions to be met by different loading units.



The unit has two outputs, allowing injection of currents as low as a few hundred milliamps and up to 750A. Voltages up to 16V are available on the 40A output, allowing higher impedance trips to be tested. Four true RMS metering ranges are provided, allowing the full scale of the meter and trip level to be set independently of the selected output. The metering has a capture time of less than 20ms, allowing the RMS of a single cycle to be accurately measured. Industry standard connectors are used on all inputs and outputs for convenience, reliability and safety.

The 750ADM-H mk3 is comprehensively protected by electronic overcurrent and thermal trips.

The timing system is very flexible without compromising ease of use, allowing trip times, reset times and reclose times to be quickly measured to a high degree of accuracy. Two contact inputs are provided, each of which may be triggered by a volt-free contact or a DC voltage. The contact inputs auto-sense for normally open or normally closed contacts.

The 750ADM-H mk3 can be used to test many devices including:

- Circuit breakers
- Primary injection of over-current relays
- Auto-reclosers
- MCB's
- CT ratio (with external meter for secondary current)

750ADM-H mk3 Specification

Main Output

The main output on the unit has two taps, allowing the selection of output voltages up to 16V and output currents up to 750A. The unit operates at slightly reduced ratings when operating from a 115V supply.

	115V	230V	
750A Output	Open circuit voltage	3.5V	5.0V
	Voltage at 500A	2.8V	4V
	Continuous current	125A	125A
	5 min on	250A	250A
	1 min on	440A	500A
	Max current	500A	750A
40A Output	Max current on time	10s	20s
	Open circuit voltage	10V	16V
	Full load voltage	7.5V	10V
	Continuous current	10A	10A
	1 min on	40A	40A

Metering

The output is metered by a digital true RMS system with a memory ammeter - whenever the output is switched off, the current reading is held on the display.

Range	Resolution	Trip current	Accuracy	Capture time
20.00A	0.01A	21A	±0.5%rdg+5d	20ms
50.00A	0.01A	53A	±0.5%rdg+5d	20ms
200.0A	0.1A	210A	±0.5%rdg+5d	20ms
750A	1A	788A	±0.5%rdg+2d	20ms

A current trip is automatically set to 105% of full scale of the selected metering range to protect the device under test.

Timing System

Range	0-999.999s/9999.99s/99999.9s auto-ranging
Resolution	1ms/10ms/100ms
Accuracy	±0.01%rdg+2d (except current operated) ±0.01%rdg+4d (current operated mode)

The contact circuits have an open circuit voltage of 24VDC and a short circuit current of 20mA. Each contact circuit will auto-select for normally open or normally closed contacts. A DC voltage of 24-240VDC may also be used to trigger either timer channel.

The following functions are provided:

Mode	Timer Start	Timer Stop
Off	Timer inactive	Timer inactive
Internal start	Press 'ON'	Contact 1
Single contact	Contact 1	Contact 1
Dual contact	Contact 1	Contact 2
Current operated	Current > 20% of range	Current < 20% of range

The output is automatically switched off at the end of the test to safeguard the relay under test.

Supply Requirements

Auto-selecting

115V±10%	50/60Hz 1ph	1900VA max
230V±10%	50/60Hz 1ph	3900VA max

RS232

An RS232 port is provided to allow connection to a PC or a printer.

Temperature Range

Storage	-20°C to 60°C	Operating	0°C to 45°C
---------	---------------	-----------	-------------

Dimensions

Peli case: 560 x 456 x 265mm

Metal case: 380 x 314 x 221mm

Weight

27.4kg

23.5kg

Accessories

Operating manual, mains lead, and carrying strap.

Optional 750ADM-AL Lead Set specifications

A range of output leads is available to complement the 750ADM-H. The standard 750ADM-AL lead set is 3m long, recommended for use with a 230V Supply. A 1.5m lead set is also available, and is recommended when operating from a 115V supply. The leads consist of double insulated 95mm² welding cable terminated in Dinse high current connectors at the 750ADM-H end and high current weldin clamps at the end.

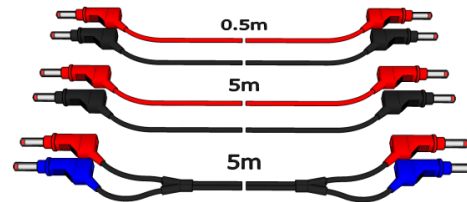

Low current timer leads are also included with the lead set:

The 3m lead set weighs 9.8kg, including high current leads and timer leads.

Protection and Safety

The unit is protected by electronic over current and thermal trips on the outputs, and circuit breakers on the input and power circuit. An earth terminal is provided for connection to a local earth when testing in a substation environment. The unit is designed to comply with BSEN61010, and is CE marked.



PCU1-SP_{mk2}

Primary Current Injection System



PCU1-SP & NLU5000 with optional trolley.

Features

- 5kA maximum output current (higher overload currents for 2s)
- Multi-function digital timing system
- True RMS memory ammeter with single cycle capture
- 200A, 2000A and 5000A loading units
- Three range outputs on loading units except NLU200*
- Direct reading CT ratio and polarity
- Optional trolley mounting of system
- Secondary injection up to 100A
- Rugged, compact design

The PCU1 series are medium powered primary current injection systems offering output currents up to 5000A. The system consists of a separate control unit containing all metering and control functions and a loading unit that provides the high current output. The PCU1-SP mk2 is ideally suited to primary current injection, stability testing and circuit breaker testing. In addition, it offers direct-reading CT ratio and polarity tests and a 100A secondary injection output. T&R also offer the higher-powered CU-PS system.

The control units are rated at 11.5kVA with a 2 second overload capability of 23kVA using pulse mode. All metering is digital and a memory facility is provided to hold the current reading when the output trips or is switched off. The PCU1 systems have a high accuracy timing system with 1ms resolution. Selection for normally open or normally closed contacts is automatic, and the status of the contacts is shown on the front panel. Timing modes are available for under and over current devices, re-closers, under and over voltage devices, current trips and circuit breakers.

Feature	PCU1-SP mk2	CU-PS
Primary injection	✓	✓
Max output power	11.5kVA 40s	20kVA 5 min
Secondary injection	✓	✗
CT ratio/polarity test	✓	✗

Three loading units are available, delivering a maximum output current of 200A, 2000A or 5000A. Each loading unit, **except NLU200**, has three output taps to allow for a wide range of load impedances. For example, the NLU5000 may be configured to either give a maximum current of 5000A on the 2.3V range, 2500A on the 4.6V range or 1250A on the 9.2V range.

PCU1-SP mk2 Specification Protection and Safety

The PCU1 series and loading units are CE marked and are designed to meet the requirements of BS EN61010. The system is protected by electronic trips on the outputs, circuit breakers on the mains input, and control unit output. The unit also has a duty cycle trip on the loading unit output and thermal protection.

Supply Requirements

230V±10%, 45-65Hz 1ph 11.5kVA max (23kVA overload for 2s)

Loading Unit Current Metering

The AC output current is metered by a true RMS memory ammeter (acquisition time 200ms) with an LCD display. The current metering has 3 ranges corresponding to 10%, 50% and 100% of the maximum rating of the loading unit. The maximum obtainable current is set by the impedance of the test object and output leads.

NLU200

Range	Full scale	Resolution	Accuracy
10%	20.00A	0.01A	±0.5%rdg+5d*
50%	100.0A	0.1A	±0.5%rdg+5d*
100%	200.0A	0.1A	±0.5%rdg+5d*

NLU2000

Range	Full scale	Resolution	Accuracy
10%	200.0A	0.1A	±0.5%rdg+5d*
50%	1000A	1A	±0.5%rdg+5d*
100%	2000A	1A	±0.5%rdg+5d*

NLU5000

Range	Full scale	Resolution	Accuracy
10%	500.0A	0.1A	±0.5%rdg+5d*
50%	2500A	1A	±0.5%rdg+5d*
100%	5000A	1A	±0.5%rdg+5d*

* ±1.5%rdg+5d pulse mode

Timing System

The PCUI systems have a flexible timing system with two contact inputs and 5 operating modes. Each contact circuit automatically selects for N/O or N/C contacts, and the status of each contact input is shown by an LED. The timing channels may also be triggered by a DC voltage between 24V and 240V.

Timer resolution	1ms
Timer full scale	999.999s
Timer accuracy	±0.01%rdg+2d (+4d current mode)
Contact O/C voltage	24V
Contact S/C current	20mA
Vdc input range	24-240Vdc

Timer mode	Timer start	Timer stop
Internal Start	'On' button	Contact
Single contact	Contact 1	Contact 1
Dual contact	Contact 1	Contact 2
Current operated	**I>20% rng	I<20% rng/Cont. 1
Pulse mode 0.2s *	'On button'	0.2s
Pulse mode 0.5s *	'On button'	0.5s
Pulse mode 1s *	'On button'	1s
Pulse mode 2s *	'On button'	2s
Off	Setting position	

***Pulse mode** applies current to the load for a maximum of the specified time. If contact set 1 changes state or the current drops below 20% of the metering range during the pulse time, the timer is stopped.

****Current operated mode** is used to time circuit breakers with no auxiliary contacts. The timer is started when the current exceeds 20% of the selected metering range (e.g. 100A on the NLU5000 500A range). The timer stops when the current falls.

Secondary Injection Output

Output Range	Continuous current	Intermittent current 5min on*	Intermittent current 1 min on*
0-5V	33A	67A	100A
0-15V	10A	20A	33A

*All on times must be followed by an off time of 15 minutes

Metering Range	Current trip	Resolution	Accuracy
10.00A	10.5A	0.01A	±0.5%rdg+5d
20.00A	21A	0.01A	±0.5%rdg+5d
100.0A	105A	0.1A	±0.5%rdg+5d

Control Unit Standard Accessories

Mains lead (5m), loading unit power and metering leads (5m), operating manual and spare fuses.

Dimensions

PCUI-SP	450 x 275 x 305mm	26kg
NLU200	450 x 275 x 370mm	49kg
NLU2000	450 x 275 x 370mm	50kg
NLU5000	450 x 275 x 370mm	60kg

Weight

Temperature Range

Storage -20°C to 60°C Operating 0°C to 45°C

Optional Loading Unit Specifications

Three loading units are available to provide a range of output currents.

NLU200 Loading Unit Intermittent Ratings

Voltage*	Current		
	Cont.	2min	40s
60V	40A	120A	200A
120V	20A	60A	100A

NLU2000 Loading Unit Intermittent Ratings

Voltage*	Current			
	Cont.	5 min	1 min	40s
4V	600A	1200A	1800A	2000A
8V	300A	600A	900A	1000A
16V	150A	300A	450A	500A

NLU5000 Loading Unit Intermittent Ratings

Voltage*	Current			
	Cont.	5 min	1 min	40s
2.3V	1500A	3000A	4500A	5000A
4.6V	750A	1500A	2250A	2500A
9.2V	375A	750A	1125A	1250A

*open circuit voltage at 230V mains

Optional Output Lead Set Specifications

Type	Length	CSA	Termination
2000NAL	1m to 5m	280mm ²	Copper bar
3000NAL**	1m to 3m	420mm ²	Copper bar
5000NAL**	1m to 3m	560mm ²	Copper bar

*Output currents above 3000A require very short leads, and longer leads will restrict the maximum current available

CU-Ps

Primary Current Injection System



Features

- 20kVA 5 minute output capability (higher overload currents for 1s)
- Multi-function digital timing
- 5000A and 6000A loading units
- Separate control and loading units
- Secondary injection up to 100A
- Direct reading CT ratio and polarity
- True RMS metering with 1 cycle capture
- Data storage to USB memory key including waveform & harmonics
- USB keyboard interface

The CU-Ps primary current injection system is ideally suited to commissioning and maintenance testing where very high currents are required. The system consists of separate control and loading units for maximum flexibility. The control unit contains all control and metering circuitry, and is linked to the loading unit by control and metering cables.

The control unit may be used with one of two loading units providing between 5000A or 6000A for 5 minutes or up to 10 or 12kA for short periods. Each loading unit has two outputs which may be connected in series or parallel for maximum flexibility. For example, the PLU-6k may be configured to either give a maximum current of 3000A at 6.6V or 6000A at 3.3V.

The control and loading units are each housed in tough steel cases fitted with castors and protective lifting handles. The loading units have a small plan area to allow them to be positioned as close as possible to the test object, minimising power requirements and maximising the available current.

The CU-Ps control unit is shown here with a PLU-6k loading unit. This combination may be used to inject currents of up to 6000A for 5 minutes or 12000A for 1 second.

This unit is ideally suited to all primary current injection tasks, including testing under and over current relays, circuit breakers and CT ratio testing.

The control unit is rated at 20kVA and has digital metering. A memory facility is provided on the metering to hold the current reading when the output trips or is switched off. The current is automatically switched off when the device under test trips.

The CU-Ps systems have a high accuracy timing system with 1ms resolution. Selection for normally open or normally closed contacts is automatic, and the status of the contacts is shown on the front panel. Timing modes are available for under and over current devices, re-closers, under and over voltage devices, current trips and circuit breakers.

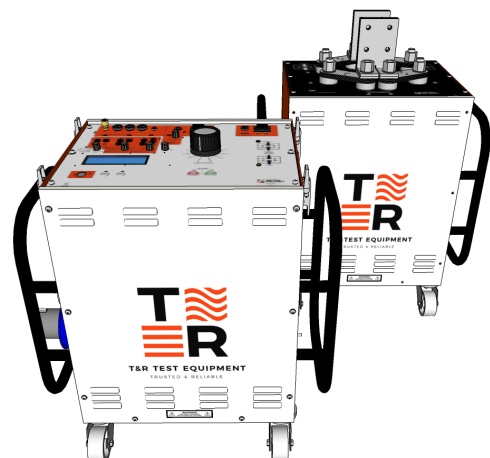

CU-Ps Specification

Loading Unit Current Metering

The AC output current is metered by a true RMS memory ammeter (acquisition time 20ms) with a liquid crystal display. The current metering has 3 ranges corresponding to 10%, 50% and 100% of the maximum rating of the loading unit. In addition, a 200% metering range is enabled in pulse mode for the 0.2s, 0.5s and 1s settings only.

PLU-5k

Range	Series Mode	Parallel Mode	Resolution	Accuracy
10%	250.0A	500.0A	0.1A	±0.5%rdg+5d
50%	1250A	2500A	1A	±0.5%rdg+5d
100%	2500A	5000A	1A	±0.5%rdg+5d
200%	5000A	10kA	10A	±1.5%rdg+5d

PLU-6k

Range	Series Mode	Parallel Mode	Resolution	Accuracy
10%	300.0A	600.0A	0.1A	±0.5%rdg+5d
50%	1500A	3000A	1A	±0.5%rdg+5d
100%	3000A	6000A	1A	±0.5%rdg+5d
200%	6000A	12kA	10A	±1.5%rdg+5d

±1.5%rdg+5d pulse mode



Timing System

The CU-Ps systems have a flexible timing system with two contact inputs and 5 operating modes. Each contact circuit automatically selects for N/O or N/C contacts, and the status of each contact input is shown by an LED. The timing channels may also be triggered by a dc voltage between 24 and 240V.

Timer resolution	1ms
Timer full scale	999.999s
Timer accuracy	±0.01%rdg+2d
Contact O/C voltage	24V
Contact S/C current	20mA
Vdc input range	24-240Vdc
Timer mode	Timer start Timer stop
Internal Start	'On' button Contact
Single contact	Contact 1 Contact 1
Dual contact	Contact 1 Contact 2
Current operated **	I >20% rng I <20% rng
Pulse mode 0.2s *	'On button' 0.2s
Pulse mode 0.5s *	'On button' 0.5s
Pulse mode 1s *	'On button' 1s
Pulse mode 2s *	'On button' 2s
Off	Setting position

*Pulse mode applies current to the load for a maximum of the specified time. If contact set 1 changes state or the current drops below 20% of the metering range during the pulse time, the timer is stopped. The maximum output current is increased in pulse mode. The maximum obtainable current is set by the impedance of the test object and output leads.

**Current operated mode is used to time circuit breakers with no auxiliary contacts. The timer is started when the current exceeds 20% of the selected metering range (e.g. 1000A on the PLU-5k 5000A range). The timer stops when the current falls.

Secondary Injection Output

Output Range	Continuous current	Intermittent current 5min on*	1 min on*
0-5V	33A	67A	100A
0-16V	10A	20A	30A

*All on times must be followed by an off time of 15 minutes

Metering Range	Resolution	Accuracy	Current trip
----------------	------------	----------	--------------

10.00A	0.01A	±0.5%rdg+5d	10.5A
20.00A	0.01A	±0.5%rdg+5d	21A
100.0A	0.1A	±0.5%rdg+5d	30A

Supply Requirements

230V±10%, 45-65Hz 1ph 23kVA 5 min/46kVA 1s

Control Unit Standard Accessories

- Spare fuse set, operating manual.
- 1 x 5m loading unit power interconnection lead.
- 1 x 5m loading unit metering interconnection lead.
- 1 x 2m mains lead.
- 1x 5m 100A leads and timer leads.

Dimensions

Control unit	660 x 400 x 740mm
PLU-5k	660 x 400 x 740mm
PLU-6k	660 x 400 x 740mm

Weight

Control unit	115kg
PLU-5k	155kg
PLU-6k	135kg

Temperature Range

Storage -20°C to 60°C, Operating 0°C to 45°C

Protection and Safety

The CU-Ps series and loading units are CE marked and are designed to meet the requirements of BS EN61010. The system is protected by electronic trips on the outputs, circuit breaker and fuse on the mains input, and a circuit breaker on the control unit output. The unit also has a duty cycle trip on the loading unit output and thermal protection.

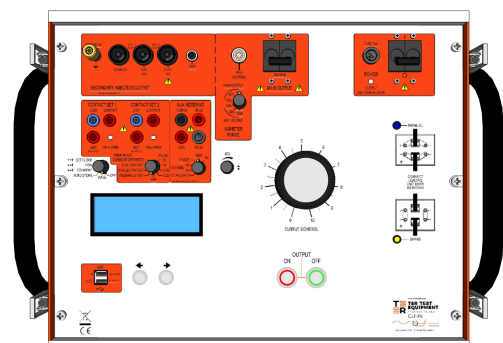

CU-Ps Specification

Loading Unit Output

The output of the loading unit is continuously variable from zero. Each unit may be operated in series/parallel mode to allow for a greater range of load impedances. All metering and tripping functions are handled by the control unit.

Primary Injection Output		PLU-5k		PLU-6k	
		Parallel mode	Series mode	Parallel mode	Series mode
Open Circuit V*		0-4V	0-8V	0-3.3V	0-6.6V
Continuous	Current	2500A	1250A	3000A	1500A
	Max kVA	10	10	10	10
5 min on/ 15 min off	Current	5000A	2500A	6000A	3000A
	Max kVA	20	20	20	20
2 sec pulse	Current	8000A	4000A	9600A	4800A
	Max kVA	32	32	32	32
1 sec pulse	Current	10000A	5000A	12000A	6000A
	Max kVA	40	40	40	40
0.5 sec pulse	Current	10000A	5000A	12000A	6000A
	Max kVA	40	40	40	40
0.2 sec pulse	Current	10000A	5000A	12000A	6000A
	Max kVA	40	40	40	40

*open circuit voltage at 230V mains

Series Mode

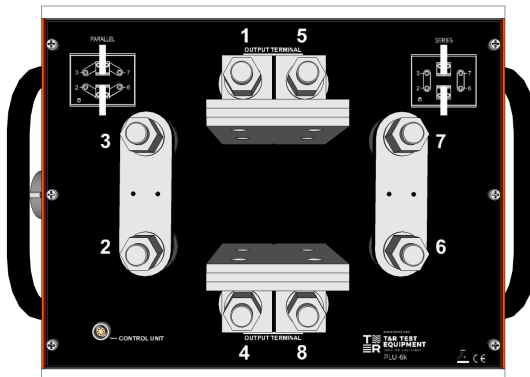

Parallel Mode

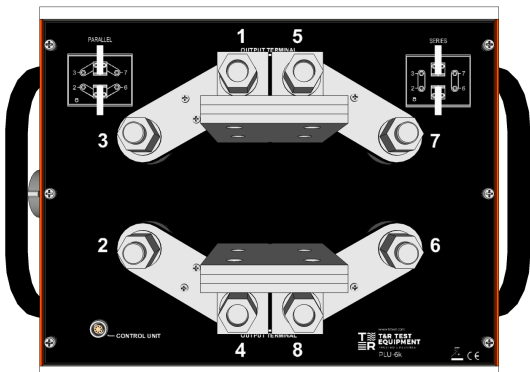

Storage of Results

All test results from the CU-Ps can be stored in a USB memory key. The unit has a real-time clock to time and date-stamp all results. To log the results, first enter a comment for your results using the optional keyboard, and then select AUTO STORE.

Whenever the timer stops, the time, current and all other parameters are added to a spreadsheet file on the USB key. You can then view the current set of results on the display or take the USB key out and open the file on your PC. All results are stored in a folder on the USB key named with the test date in a file named with the time.

Sample data stored on USB key

Time,	Date,	Main A,	Timer,	Aux A,	Aux V,	Phase,	Freq Hz,	Comment
10:53:12,12/12/18,	2050,	10.000,	0.000,	10.0,	10.3,	50.00,	Breaker 12	
10:53:30,12/12/18,	5120,	3.000,	0.000,	10.0,	10.3,	50.00,	Breaker 12	
10:54:10,12/12/18,	1020,	1.000,	0.000,	10.0,	10.3,	50.00,	Breaker 12	

Also the CU-Ps can store a .CSV file of the waveform

Optional Output Lead Set Specifications

A range of output lead sets are available to complement the CU-Ps system with current ratings between 3000A

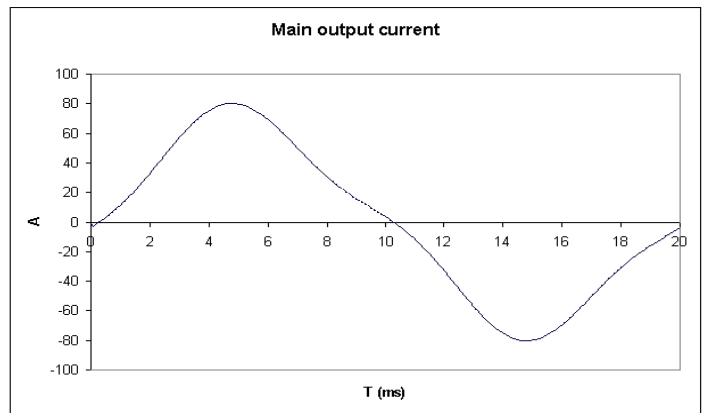

and 6000A. The leads are double insulated and have good flexibility.

Type	Length	CSA	Termination
3000AL	2.5m	560mm ²	Copper bar
4000AL	2.5m	700mm ²	Copper bar
5000AL	2m	840mm ²	Copper bar
6000AL	2m	1120mm ²	Copper bar

Other output lead lengths are available on request.

Output currents above 3000A require very short leads, and longer leads will restrict the maximum current

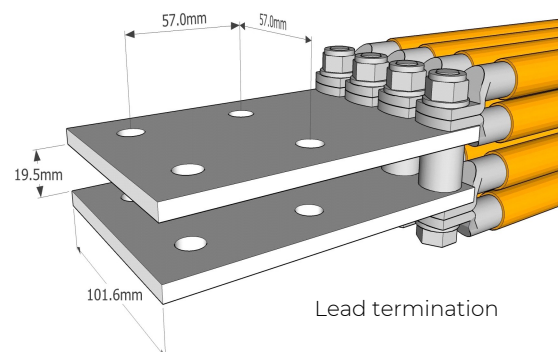

DP20 DP40

High Voltage DC Discharge Probes



Features

- For discharging high voltage cables after testing
- Earthing hook
- Highly flexible, clear silicone covered earth cable
- For use with the PT18-10 and PT30-10 cable test sets

The DP20 and DP40 discharge probes are designed for discharging high voltage cables after testing. The probes are supplied as standard accessories for the T&R PT18-10 and PT30-10 cable test sets, and are also available separately.

The discharge probes consist of a pointed probe connected to a 5m long earth lead via a series of surge resistors with an insulated handle. The earth lead insulation is clear silicone allowing the conductor to be easily inspected, and is terminated in an M6 hooked crimp.

	DP20	DP40
Maximum discharge voltage	20kV	40kV
Maximum discharge energy	3.6kJ	7.2kJ
Maximum discharge capacitance	12µF	6µF
Resistance	30kΩ	60kΩ
Length	530mm	900mm
Earth lead length	5m	5m
Earth lead CSA	6mm ²	6mm ²

ES30 ES50 ES100

Earth Sticks



Features

- For earthing high voltage connections
- Highly flexible, clear silicone covered earth cable

The ES30, ES50 and ES100 earthing sticks are designed for earthing the high voltage connection after AC testing in accordance with BS-EN50191.

The earthing sticks consist of a hooked earth connection mounted on an insulated handle with a 5m earth lead.

The earth lead insulation is clear silicone allowing the conductor to be easily inspected, and is terminated in an M6 hooked crimp.

	ES30	ES50	ES100
Maximum voltage	30kV	50kV	100kV
Length	670mm	840mm	1270mm
Earth lead length	5m	5m	5m
Earth lead CSA	6mm ²	6mm ²	6mm ²

Each of the earth sticks unscrews into two sections for easy storage and transport.

Note: Under no circumstances must these discharge/earthing probes be used on energised distribution systems.

Z-OVR

Cable Impedance Test System



Features

- Measure impedance of overhead lines and underground cables
- Direct readout of cable Z & X
- Phase angle display
- Voltage up to 300V
- Current up to 80A
- Data storage to CSV file on USB memory key
- Digital true RMS memory ammeter & voltmeter
- Solid state switching
- Rugged, compact design

The Z-OVR is a cable impedance test system for the measurement of impedance of overhead lines and underground cables. The system consists of a separate control unit containing all metering and control functions and an output transformer that provides isolation of the output current and feedback voltage.

A current is injected into the line under test and the resultant magnitude and phase angle of the voltage across the line is measured. The current, voltage, phase angle and impedance of the line (Z & X) under test are displayed. In addition, the harmonic content of the voltage and current can be displayed.

The unit has data logging facilities using a standard USB memory key. Date, time, current, voltage, phase angle, and frequency are stored to a CSV file on the memory key along with a comment entered using the supplied USB keyboard. Pressing the "store" pushbutton causes a new set of values to be written to the CSV file.

The output has three taps (75V, 150V & 300V), allowing the measurement of impedance of a wide range of lines and cables. All metering is true RMS. Four current ranges (2.000, 10.00, 20.00 and 100.0A) and two voltage ranges (30.00V and 300.0V) are provided.

The output transformer unit uses 6mm safety connectors for all outputs and 4mm safety connectors for inputs. A block of connectors is provided adjacent to the output to allow easy parallel connection of cables for parallel measurements on all three phases.

The unit is provided with a set of four 10m 12mm² duplex measurement cables. These provide a 12mm² conductor for current injection and a 6mm² conductor for voltage feedback in each cable.



Z-OVR Specification

The AC output current and load voltage are measured by a true RMS metering system with hold facility. All readings are held when the output is switched off. Four current ranges and two voltage metering ranges are provided.

Range	Full scale	Resolution	Accuracy
2A	2.000A	0.001A	±1%rdg+5d
10A	10.00A	0.01A	±1%rdg+5d
20A	20.00A	0.01A	±1%rdg+5d
100A	100.0A	0.1A	±1%rdg+5d
30V	30.00V	0.01V	±1%rdg+5d
300V	300.0V	0.1V	±1%rdg+5d
Phase	0-±180.0°	0.1°	±1°

Output ratings

Current rating

Output	Continuous	5 min on	Maximum
75V 80A	40A	80A	80A
150V 40A	20A	40A	40A
300V 20A	10A	20A	20A

Data Storage

All test results from the Z-OVR can be stored on a USB memory key. The unit has a real-time clock to time and date-stamp all results. To log results first enter a comment for the results using the USB keyboard, and then select 'auto store'. Whenever the 'store' key is pressed the current, voltage and all other parameters are added to a spreadsheet file on the memory key. The current set of results can be viewed on the display. All results are stored in a folder on the USB key named with the test date in a file named with the time. In addition, the Z-OVR can store the voltage and current waveforms to the USB key in CSV format.

Sample data stored to USB key

```
"Z-OVR", "V1.05", "C00", "P1", "A1"
"Time", "Date", "Amps", "Volts", "Phase", "Freq Hz", "Z", "X", "Comment"
"11:18:40", "21/09/18", "10.00", "1.000", "90.0", "0.1000", "0.1000", "Cable Sub xx to yy phase A-B"
"11:19:42", "21/09/18", "10.00", "1.000", "90.0", "0.1000", "0.1000", "Cable Sub xx to yy phase B-C"
"11:20:49", "21/09/18", "10.00", "1.000", "90.0", "0.1000", "0.1000", "Cable Sub xx to yy phase C-A"
"11:20:49", "21/09/18", "10.00", "1.000", "90.0", "0.1000", "0.1000", "Cable Sub xx to yy ABC-E"
```

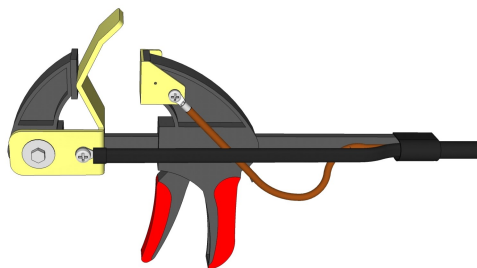

Overhead line Kelvin connection clamp

Unit	Dimensions	Weight
Z-OVR	450 x 275 x 305mm	26kg
NLU75/80	450 x 275 x 330mm	49kg

Temperature Range

Storage -20°C to 60°C Operating 0°C to 45°C

Protection and Safety

Isolation is provided on all outputs and inputs to be connected to the line under test.

The Z-OVR system is CE marked and is designed to meet the requirements of BS EN61010. The system is protected by electronic trips on the outputs, circuit breakers on the mains input and output. The unit also has a duty cycle trip on the loading unit output and comprehensive thermal protection.

Supply Requirements

230V±10% 45-65Hz 1ph 7kVA max

Standard Accessories

- Mains lead (5m).
- Power and metering interconnection leads (5m).
- Earth lead.
- 3 x 10m overhead line Kelvin connection leads.
- 1 x 10m earth Kelvin connection lead.
- Link lead to connect parallel connection block.
- USB keyboard, USB memory key.
- Operating manual.
- Spare fuses.

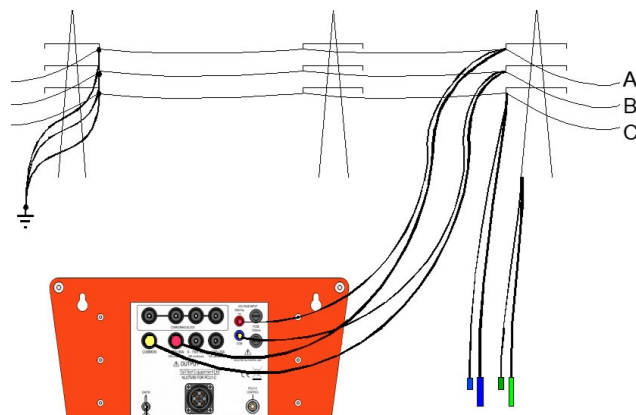

Phase A to phase B impedance test

KV5-100 mk3

High Voltage AC Test System



Features

- Continuously variable output voltage 0-5kVac
- Variable trip circuit 2-12mA and 20-120mA
- Output voltage and current metering
- Visual and audible indication of test piece failure
- Compact lightweight instrument
- Burn feature giving 100mA maximum current on short circuit
- Key operated switch preventing unauthorised operation
- Complies with the testing requirements of BS1363

T&R Test Equipment is a market leader in the field of protection test equipment. The range includes primary and secondary current injection equipment up to 6000A, voltage sources, micro-ohmmeters and high voltage test systems up to 100kV.

The KV5-100 mk3 high voltage test set is a general purpose test instrument designed for testing insulation systems and the measurement of breakdown voltage on electrical plant and components.

The unit has an output voltage adjustable from zero to 5kV with accurate metering on both the output voltage and current. A zero-voltage interlock is provided, ensuring that the output may only be energised with the voltage control at zero.

The output voltage is metered by a large, linear analogue instrument with a dual-scale marking of 0-3kV and 0-6kV. Load current is metered by a second analogue instrument with 0-10 scale marking. Two current ranges are selectable: 0-10mA and 0-100mA.

The test object and output are protected by an adjustable current trip linked to the current metering range. The trip level may be set to 20-120% of the current metering range on 20% steps.

Breakdown of the test object is both audibly and visibly indicated. The alarm must be manually reset after a trip condition before testing can be resumed.

The instrument is supplied in a compact and portable case with permanently connected test leads. The test leads are terminated in clips. The unit is designed for operation in conjunction with a suitable interlocked test enclosure or high voltage test area.

KV5-100 mk3 Specification

Output

The main output on the unit is variable between 0 and 5kVac. The output is rated at 50mA continuously and 100mA for 5 minutes followed by an off time of 15 minutes.

Metering

The output voltage is metered by an analogue instrument with 0-3kV and 0-6kV scaling.

Range	Accuracy
3kV	±1.5% of FS
6kV	±1.5% of FS

The output current is metered by a dual range analogue instrument with 0-10mA and 0-100mA ranges. The current trip may be set to 20-120% of the selected range in 20% steps.

Range	Trip Current	Accuracy
10mA	2-12mA	±3% of FS
100mA	20-120mA	±3% of FS

Overload Protection

An electronic overload protection circuit is provided on the KV5-100 mk3, backed up by a fuse. The trip current is user selectable, and allows values between 2mA and 120mA to be set. A trip condition is indicated by an illuminated push button and an audible alarm.

Burn Circuit

When in circuit, the maximum short circuit current is limited to 100mA. When out of circuit, the maximum short circuit current is approximately 2A.

Output connections

The KV5-100 mk3 is provided with battery clips for connection to the object under test. The unit is designed to be operated in conjunction with an interlocked test enclosure ensuring safety for the user.

Interlock Circuits

The unit has a zero volt interlock that prevents the output being energised unless the output control is in the zero position. An external interlock connection is also provided, allowing the fitting of external emergency off buttons and test enclosure/cage door interlocks.

Supply Requirements

115V±10%	50/60Hz	1ph	600VA max
240V±10%	50/60Hz	1ph	600VA max

Protection and Safety

The unit is protected by electronic over current trips on the outputs and a fuse on the mains. An earth terminal is provided for connection to a local earth.

The unit is designed to comply with BSEN61010, and is CE marked. The unit must be installed to the requirements of BS EN50191.

Temperature Range

Storage	-20°C to 60°C	Operating	0°C to 45°C
----------------	---------------	------------------	-------------

Dimensions

364 x 147 x 262mm

Weight

16.5kg

Accessories

Operating manual, mains lead, spare fuse.

Variants

Other voltages and ratings for this unit are available as special products on request. Such as the KV4-300, a unit with a 4kV, 300mA rating. Units have also been supplied with a 3kV 250mA rating. If you would like a quote for your specific requirements please contact us.

The KV5-100 mk3 is one of a range of high voltage test systems available from T&R Test Equipment.



*KV50-100 mk3
output transformer.*

Unit type	Voltage	Current
KV5-100 mk3	5kV	100mA
KV15-80D	15kV	80mA
KV30-40D mk3	30kV	40mA
KV30-100 mk3	30kV	100mA
KV50-100 mk3	50kV	100mA
KV50-200 mk3	50kV	200mA
KV100-100 mk3	100kV	100mA

KV30-40D_{mk3}

High Voltage AC Test System



Features

- 0-30kV output voltage
- Automatic mains voltage selection
- Key operated supply switch to prevent unauthorised operation
- Dual overload protection
- Variable electronic trip - 10-110% of rated output
- Voltage and current digital metering
- Zero-volt interlock
- External 24VDC interlock circuit
- Test timer
- Emergency stop
- Visual indication of test piece failure

The KV30-40D mk3 high voltage AC test set is a general purpose test instrument designed for testing insulation systems and the measurement of breakdown voltage on electrical plant and components.

A test timer is provided for pre-selectable test times of 5 seconds to 5 minutes.

The unit is supplied in a compact, portable case with a permanently connected 2 metre long HV output lead.

Maximum Voltage	Maximum current	kV meter resolution	mA meter resolution
30kV	40mA	0.01kV	0.02mA

The output voltage is variable up to 30kV. A zero-voltage interlock is provided, ensuring that the output may only be energised with the voltage control at zero. The output voltage and current are metered by large true RMS reading digital meters.

The unit features automatic mains voltage selection and an external 24VDC interlock circuit for connection of emergency-off switches and interlock switches on the test enclosure.

The test object and output are protected by an adjustable electronic current trip. The trip level may be set to 10-110% of the rated output in 10% steps. Breakdown of the test object is visibly indicated and the unit must be manually reset after a trip condition before testing can be resumed.



KV30-40D mk3 Specification

Supply Requirements

115V/230V±10% auto-selecting
50/60Hz 1ph 1200VA max

Output

The output of the KV30-40D mk3 is supplied via a permanently connected partially screened high voltage cable. This stows in the lid for transit along with the ES30 earthing stick.

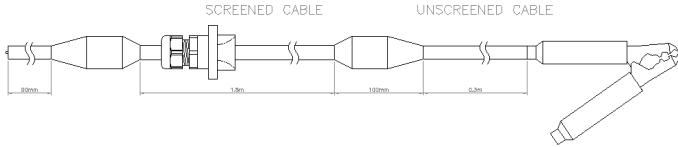

The output of the KV30-40D mk3 is rated at 40mA on a duty cycle of 5 minutes on/15 minutes off or 20mA continuously. These ratings are based on an ambient temperature of 25°C.

Metering

The output voltage and current are metered by large, accurate true RMS digital meters. The meters are backlit and have a digit height of 8mm and analogue simulation.

Test Timer

A pre-selectable test timer is provided for timed tests of 5, 10, 15, 20, 30 seconds, 1, 2, 3 or 5 minutes. An alarm sounds when the test time has ended.

Overload Protection

Two overload protection circuits are provided on the units. The first is user selectable, and allows trip currents between 10% and 110% of the rated output to be set. A trip condition is indicated by an illuminated push button and an audible alarm. The second trip circuit is a magnetic circuit breaker operating on the primary of the HV transformer. This operates on large overloads (such as flashovers).

Accessories supplied with unit

Supply lead, spare fuse set, operating manual, 5m earth lead, ES30 earthing stick.



ES30 Earthing stick

Protection and Safety

In addition to the output protection the input and control supplies are protected by fuses.

All units are designed to meet the requirements of BS EN61010.

An earth terminal is provided on the transformer which must be connected to a low impedance local earth.

An emergency stop will cut all power to the output, when activated.

Temperature Range

Storage -20°C to 60°C

Operating 0°C to 45°C

Dimensions

300 x 400 x 470mm

Weight

42kg

Special Products

If you require a different output voltage test system, please contact us with your specification and we will quote for a custom design.

The KV30-40D mk3 is one of a family of 1200VA high voltage units spanning the range 6kV 200mA to 30kV 40mA. All supplied with digital metering

Unit	Maximum Voltage	Maximum current
KV6-200D	6kV	200mA
KV10-120D	10kV	120mA
KV15-80D	15kV	80mA
KV30-40D mk3	30kV	40mA



High voltage test systems are also available from T&R Test Equipment up to 100kV @ 100mA.

VC24-24_{mk2}

24kV Vacuum Bottle Check System



Features

- 0-24kV output voltage
- 24mA maximum output current
- Automatic mains voltage selection
- Key operated supply switch to prevent unauthorised operation
- Dual overload protection
- Variable electronic trip - 16, 20, 24mA
- Voltage and current metering
- Zero-volt interlock
- Emergency stop
- Visual indication of test piece failure

The VC24-24 is a general purpose high-voltage AC test set, ideal for Flash Testing of plant and switchgear, such as circuit breaker vacuum bottles, with voltages up to 24kV AC.

The output voltage is variable from zero to 24kV. A zero-voltage interlock is provided, ensuring that the output may only be energised with the voltage control at zero.

Unit	Maximum Voltage	Maximum current	kV meter full scale	mA meter full scale
VC24-24	24kV	24mA	30kV	3mA/30mA

The unit features automatic mains voltage selection and an emergency-off switch.

The output voltage and current are metered by large, linear analogue instruments. The unit has a x0.1 range on the mA meter. The mA meter is marked with a green scale for currents under 10mA and a red scale for currents larger than 10mA.

The test object and output are protected by an adjustable electronic current trip. The trip level may be set to 16, 20 or 24mA. Breakdown of the test object is visibly indicated and the unit must be manually reset after a trip condition before testing can be resumed.

The unit is supplied in a compact, portable case with a permanently connected 2 metre long HV output lead.

VC24-24 Specification

Output

The output of the VC24-24 is by a 2 metre long permanently connected partially screened high voltage cable terminated in a large clip.

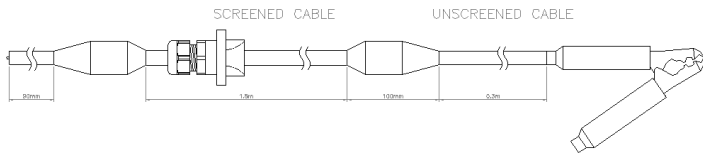

Output Ratings

Unit	Output Voltage	Current (continuous)	Current (5 min)
VC24-24	0-24kV	15mA	24mA

The above intermittent on times must be followed by an off time of 15 minutes, and are based on an ambient temperature of 25°C.

Metering

The output voltage and current are metered by large analogue instruments, with dual ranges on the current meter.

Meter	Low range full scale	High range full scale	Accuracy
kV meter	-	30kV	±2% of FS
mA meter	3mA	30mA	±2% of FS

Supply Requirements

115V/230V±10% auto-selecting 50/60Hz 1ph 650VA max.



ES30 Earthing stick

Overload Protection

Two overload protection circuits are provided on the unit. The first is user selectable, and allows trip currents of 16, 20 or 24mA to be set. A trip condition is indicated by an illuminated push button that must be pressed before testing can continue.

The second trip circuit is a magnetic circuit breaker operating on the primary of the HV transformer. This operates on large overloads (such as flashovers).

Protection and Safety

In addition to the output protection the input and control supplies are protected by fuses.

All units are designed to meet the requirements of BS EN61010.

An earth terminal is provided on the unit which must be connected to a low impedance local earth.

Temperature Range

Storage -20°C to 60°C **Operating** 0°C to 45°C

Dimensions

300 x 400 x 470mm

Weight

27kg

Accessories

Supply lead, spare fuse set, operating manual, 5m earth lead, ES30 earthing stick.

The VC24-24 is one of a family of high voltage units spanning the range 6kV 200mA to 30kV 40mA.

Unit	Maximum Voltage	Maximum current
KV6-200D	6kV	200mA
KV10-120D	10kV	120mA
KV15-80D	15kV	80mA
KV30-40D mk3	30kV	40mA

High voltage test systems are also available from T&R Test Equipment up to 100kV, 100mA.



KV100-100

KV50-20D_{mk3}

High Voltage AC Test System

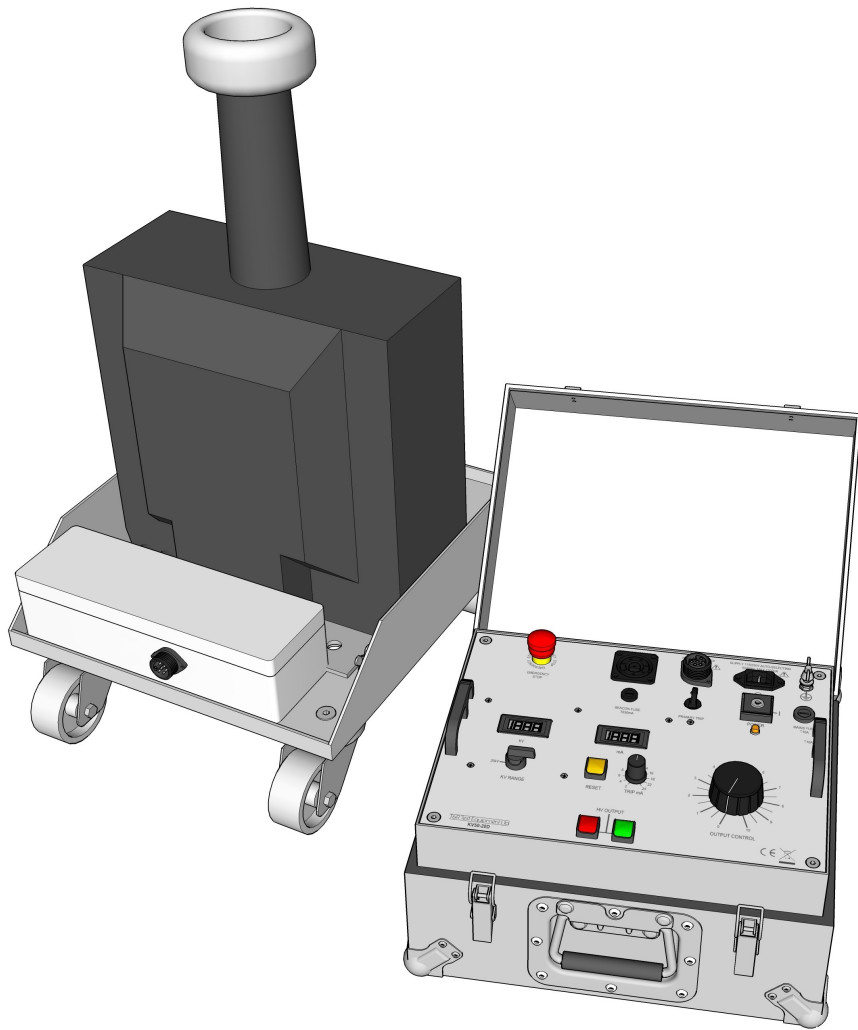

Features

- 0-50kV output voltage
- 20mA maximum output current
- Auto-selecting 115/230V supply voltage
- Key operated supply switch to prevent unauthorised operation
- Dual overload protection
- Variable electronic trip
- Voltage and current metering
- External interlock circuit
- Zero-volt interlock
- Visual indication of test piece failure
- Cast resin HV transformer

The KV50-20D is a low power portable high voltage AC test system designed for insulation testing. This system is equally suited to both development and routine testing of electrical insulation systems and plant.

The equipment consists of a control unit and a separate resin cast high voltage transformer linked by a 5 metre control cable. The control unit is housed in a rugged aluminium case with a hinged, removable lid for protection. The high voltage transformer is mounted on a base with swivel castors for mobility.

The control unit is fitted with a comprehensive range of facilities for control, metering and protection, including an emergency off switch. The output RMS voltage and current are displayed on digital meters. A variable electronic trip is provided, allowing the trip current to be set to 10-110% of rated output.

The unit is designed to be operated with the HV transformer inside an interlocked test enclosure. A connector is supplied on the control unit to connect interlock switches, extra emergency stop switches and external 24V beacons.

KV50-20D Specification

Output

The output of the KV50-20D is via a high voltage bushing. The bushing is designed to be connected to the object under test by an air insulated connection such as copper tubing or tinned copper wire (not supplied with the system). The earthy end of the HV winding is connected to earth via the current metering circuit.

Output voltage 0-50kVac

Output current 12mA continuous
20mA 5 min on/15min off

Metering

The output voltage is metered by a true RMS digital instrument.

	20kV range	50kV range
Full scale	19.99kV	50.00
Resolution	0.01kV	0.1kV
Accuracy (no load)	±2% of rdg + 5d	±2% of rdg + 5d
Accuracy (@12mA)	±5% of rdg + 5d	±5% of rdg + 5d

Load current is metered by a true RMS digital instrument.

	20mA range
Full scale	19.99mA
Resolution	0.01mA
Accuracy (no load)	±2% of rdg + 5d
Accuracy (@12mA)	±5% of rdg + 5d

Control

The output voltage is set by a continuously variable output control with a zero volt interlock - the output may only be switched on with the control in the zero position. The output voltage is switched on and off by illuminated push button switches.

The mains supply switch for the unit is a key operated switch. The key is trapped in the switch in the 'on' position.

Supply requirements

115/230V±10% auto-selecting 50/60Hz 1ph 1.5kVA.

Protection and safety

The output of the units are protected by variable electronic trips monitoring the output current, and a fixed over-current trip on the primary of the output transformer. The variable trip is adjustable in 10% steps between 10% and 110% of the rated output current.

The input and control supplies are protected by fuses.

The KV50-20D is designed to meet the requirements of BS EN61010. The unit must be installed in a high voltage test area complying with the requirements of BS EN50191.

Earth terminals are provided on the control unit and HV transformer that must be connected to a low impedance local earth.

Interlock circuits

Two interlock circuits are provided on the KV50-20D. A zero voltage interlock is fitted which prevents the HV output being energised unless the output voltage control is in the zero position. An external interlock circuit is also provided, allowing the fitting of external emergency off buttons and test cage door interlocks.

Beacon output

A beacon output is provided on the control unit to control 24V beacons (max 0.5A). The beacons mimic the state of the HV on and off indicators on the unit—green for HV off and red for HV on.

Temperature Range

Storage 20°C to 60°C **Operating** 0°C to 45°C

	Dimensions	Weight
Control Unit	380 x 314 x 221mm	17kg
Transformer	490 x 520 x 795mm	75kg

Accessories

- 1 x 2m power supply lead
- 1 x 5m interconnecting lead
- 1 x 3m test object earth lead
- 1 x 5m earth lead
- Spare fuse set
- Operating manual

KV30-100 mk3 / KV50-100 mk3

High Voltage AC Test Systems

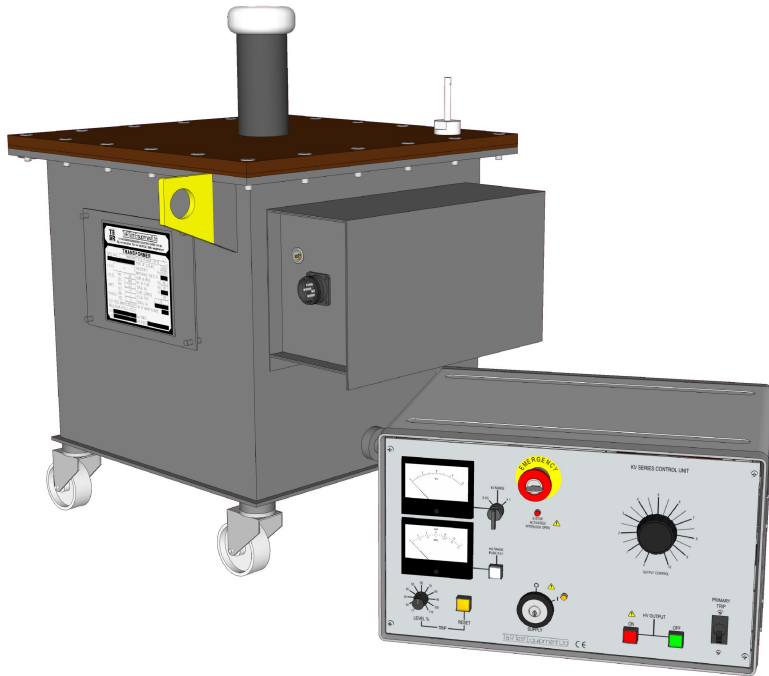

Features

- 0-30kV (KV30-100 mk3) or 0-50kV (KV50-100 mk3) output voltage
- 3kVA (KV30-100 mk3) or 5kVA (KV50-100 mk3) output capability
- Key operated supply switch to prevent unauthorised operation
- Dual overload protection
- Variable electronic trip - 10 -110% of rated output
- Voltage and current metering
- External interlock circuit
- Zero-volt interlock
- Visual indication of test piece failure

The KV30-100 mk3 and KV50-100 mk3 are high power, high voltage AC test systems designed for insulation testing. These systems are equally suited to both development and routine testing of electrical insulation systems and plant.

The equipment consists of a control unit and a separate oil filled high voltage transformer, linked by a 5 metre supply and control cables. The control unit is fitted with a comprehensive range of facilities for control, metering and protection. The output voltage and current are displayed on large, linear analogue instruments, and a variable electronic trip is provided, allowing the trip current to be set to 10-110% of rated output.

The high voltage transformer is housed in an oil-filled steel tank fitted with swivel castors for mobility. The units use a high voltage bushing for the HV output, and the other end of the HV winding is earthed. Both the KV30-100 mk3 and KV50-100 mk3 are equally suited to testing capacitive, resistive or inductive test objects.

If higher voltage or output power is required, please refer to our KV50-200 mk3/KV100-100 mk3 data sheet, detailing our 10kVA high voltage systems.



KV30-100 mk3 / KV50-100 mk3 Specification

Output

The output of the KV series units is by a high voltage bushing. The bushing is designed to be connected to the object under test by an air insulated connection such as copper tubing (not supplied with the system). The earthy end of the HV winding is connected to earth via the current metering circuit.

Continuous Ratings

	KV30-100 mk3	KV50-100 mk3
Voltage	0-30kVac	0-50kVac
Current	50mA	50mA
Power	1.5kVA	2.5kVA

Intermittent Ratings (5 min. on/15 min. off)

	KV30-100 mk3	KV50-100 mk3
Voltage	0-30kVac	0-50kVac
Current	100mA	100mA
Power	3kVA	5kVA

If you require a different output voltage test system, please contact us with your specification and we will quote for a custom design.

Metering

The output voltage is metered on the primary of the HV transformer, connected to an average-reading dual scaled analogue instrument.

	x0.5 range	x1 range	Accuracy
KV30-100 mk3	0-20kV	0-40kV	±2% of FS
KV50-100 mk3	0-30kV	0-60kV	±2% of FS

The accuracies shown for voltage metering are for no-load conditions.

Load current is metered in the earthy end of the HV winding by an average-reading analogue instrument.

	mA Meter	Accuracy
KV30-100 mk3	0-120mA	±2% of FS
KV50-100 mk3	0-120mA	±2% of FS

Control

The output voltage is set by a continuously variable output control with a zero volt interlock - the output may only be switched on with the control in the zero position. The output voltage is switched ON and OFF by illuminated push button switches.

The mains supply switch for the unit is a key operated switch. The key is trapped in the switch in the ON position.

Supply Requirements

KV30-100 mk3 230V±10% 50/60Hz 1ph 3.5kVA max
KV50-100 mk3 230V±10% 50/60Hz 1ph 6kVA max

Protection and Safety

The output of the units are protected by variable electronic trips monitoring the output current, and a fixed over-current trip on the primary of the output transformer. The variable trip is adjustable in 10% steps between 10% and 110% of the rated output current.

The input and control supplies are protected by fuses.

The KV30-100 mk3 and KV50-100 mk3 are designed to meet the requirements of BS EN61010. The unit must be installed in a high voltage test area complying with the requirements of BS EN50191.

An earth terminal is provided on the transformer which must be connected to a low impedance local earth.

Interlock Circuits

Two interlock circuits are provided on the kV series test systems. A zero voltage interlock is fitted which prevents the HV output being energised unless the output voltage control is in the zero position. An external interlock circuit is also provided, allowing the fitting of external emergency off buttons and test cage door interlocks. The KV30-100 mk3 and KV50-100 mk3 external interlocks operate at 230Vac.

Temperature Range

Storage -20°C to 60°C

Operating 0°C to 45°C

	Dimensions	Weight
KV30-100 mk3 Control Unit	370 x 480 x 290mm	25kg
KV50-100 mk3 Control Unit	370 x 480 x 290mm	25kg
KV30-100 mk3 Transformer	480 x 460 x 570mm	210kg
KV50-100 mk3 Transformer	490 x 520 x 795mm	230kg

Accessories

1 x 5m Power interconnecting lead

2 x 5m Metering interconnection leads

Spare fuse set, operating manual

Optional Accessories

Test duration timer (must be specified at the time of ordering).

KV50-200_{mk3} / KV100-100_{mk3}

High Voltage AC Test Systems



Features

- 0-100kV (KV100-100 mk3) or 0-50kV (KV50-200 mk3) output
- 10kVA output capability
- Key operated supply switch to prevent unauthorised operation
- Dual overload protection
- Variable electronic trip 10-110% of rated output
- Voltage and current metering
- External interlock circuit
- Zero-volt interlock
- Visual indication of test piece failure

The KV50-200 mk3 and KV100-100 mk3 are high power, high voltage AC test systems designed for insulation testing. These systems are equally suited to both development and routine testing of electrical insulation systems and plant. Each unit is available in either a low partial discharge version or without a specified discharge level.

The equipment consists of a control unit and a separate oil filled high voltage transformer, linked by a 5 metre supply and control cables. The control unit is fitted with a comprehensive range of facilities for control, metering and protection.

Both systems include secondary tap metering as standard to ensure accurate voltage metering. The output voltage and current are displayed on large, linear analogue instruments, and a variable electronic trip is provided, allowing the trip current to be set to 10-110% of rated output.

The high voltage transformer is housed in an oil-filled steel tank fitted with swivel castors for mobility. The units use a low-discharge oil-filled bushing for the HV output. Both the KV50-200 mk3 and KV100-100 mk3 are equally suited to testing capacitive, resistive or inductive test objects. The partial discharge levels on the standard KV50-200 mk3 and KV100-100 mk3 are not specified.

KV50-200 mk3 / KV100-100 mk3 Specifications

Output

The output of the KV series units is by an oil filled high voltage bushing. The bushing is designed to be connected to the object under test by an air insulated connection such as copper tubing (not supplied with the system). The earthy end of the HV winding is connected to earth via the current metering circuit and a removable link. The removable link allows equipment supplied by the user to be connected into the earthy end of the HV winding for Tan- δ measurements.

Continuous Ratings

	KV50-200 mk3	KV100-100 mk3
Voltage	0-50kVac	0-100kVac
Current	100mA	50mA
Power	5kVA	5kVA

Intermittent Ratings (5 minutes on/15 minutes off)

	KV50-200 mk3	KV100-100 mk3
Voltage	0-50kVac	0-100kVac
Current	200mA	100mA
Power	10kVA	10kVA

If you require a different output voltage test system, please contact us with your specification and we will quote for a custom design.

Metering

The output voltage is metered using a tap on the HV winding connected to an average-reading dual scaled analogue instrument.

	x0.5 range	x1 range	Accuracy
KV50-200 mk3	0-30kV	0-60kV	$\pm 2\%$ of FS
KV100-100 mk3	0-60kV	0-120kV	$\pm 2\%$ of FS

Load current is metered in the earthy end of the HV winding by an average-reading analogue

	mA Meter	Accuracy
KV50-200 mk3	0-240mA	$\pm 2\%$ of FS
KV100-100 mk3	0-120mA	$\pm 2\%$ of FS

instrument.

Control

The output voltage is set by a continuously variable output control with a zero volt interlock - the output may only be switched ON with the control in the zero position. The output voltage is switched ON and OFF by illuminated push button switches.

The mains supply switch for the unit is key operated.

The key is trapped in the switch in the ON position.

Supply Requirements

230V $\pm 10\%$ 50/60Hz 1ph 11kVA max

Protection and Safety

The output of the units are protected by variable electronic trips monitoring the output current, and a fixed over-current trip on the primary of the output transformer. The variable trip is adjustable in 10% steps between 10% and 110% of the rated output current.

The input and control supplies are protected by fuses.

The KV50-200 mk3 and KV100-100 mk3 are designed to meet the requirements of BS EN61010. The unit must be installed in a high voltage test area complying with the requirements of BS EN50191.

An earth terminal is provided on the transformer which must be connected to a low impedance local earth.

Interlock Circuits

Two interlock circuits are provided on the kV series test systems. A zero voltage interlock is fitted which prevents the HV output being energised unless the output voltage control is in the zero position. An external interlock circuit is also provided, allowing the fitting of external emergency off buttons and test cage door interlocks.

Temperature Range

Storage -20°C to 60°C Operating 0°C to 45°C

Dimensions

Weight

KV50-200 mk3 Control Unit	370 x 480 x 290mm	37kg
KV100-100 mk3 Control Unit	370 x 480 x 290mm	37kg
KV50-200 mk3 Transformer	570 x 500 x 1020mm	220kg
KV100-100 mk3 Transformer	730 x 650 x 1350mm	390kg

Accessories

- 1 x 5m Power interconnecting lead
- 2 x 5m Metering interconnection leads
- Spare fuse set, operating manual

Optional Accessories

Test duration timer (must be specified at the time of ordering).



HV TROLLEY2

High Voltage AC Test System

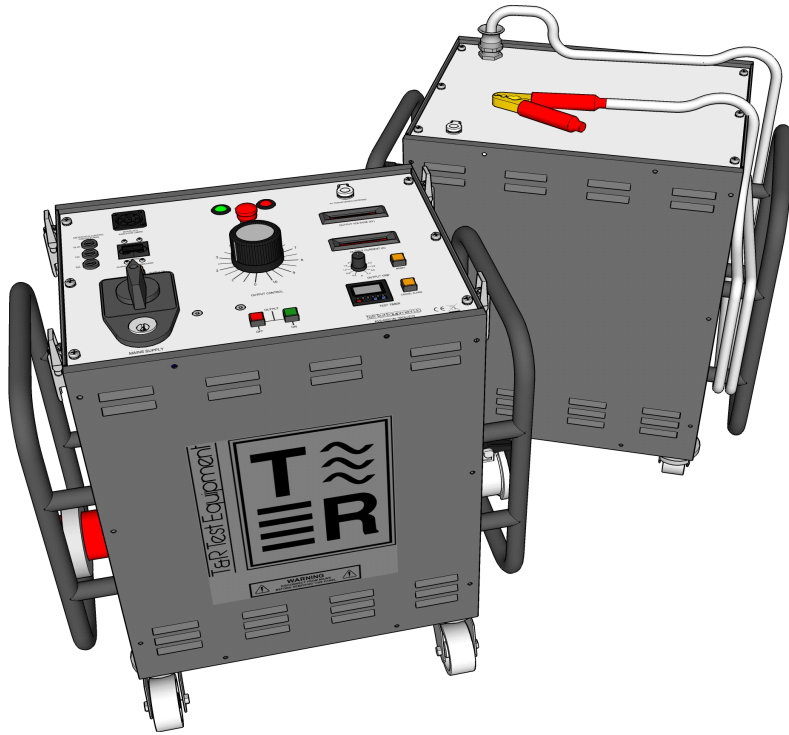

Double Trolley Version

Features

- 20kVA output capability
- 0-3kV to 0-15kV options available
- Accurate digital metering
- Key operated supply switch
- Dual overload protection
- Variable electronic trip 10-110% of rated output
- Voltage and current metering
- Optional 5s - 5min test timer
- External 24V interlock and zero-volt interlock
- Emergency stop switch



Single Trolley Version

The HV trolley2 series of units are high power AC flash test sets with a 20kVA output capability. The maximum output voltage can be customised to be any voltage up to 15kV. The unit is housed in a rugged aluminium enclosure with a cover to protect the control panel. It is mounted on wheels to allow easy movement within a production environment.

The HV trolley2 is provided with accurate digital voltage and current metering and a variable electronic trip. An external interlock input is also fitted to the unit. Outputs are provided to drive 24V warning beacons. The HV output is connected to the test object by a high voltage cable 5m long.

HV Trolley2 Specification

Output

The output of the HV Trolley2 series units is by a 5m long screened high voltage cable terminated in a large clip. A 5m long silicone covered earth lead is provided for the earth connection to the test object.

Unit	Output voltage	Continuous rating	5 min on/ 15 minutes off
KV3-7000/2	0-3kV	3.5A	7.0A
KV5-4000/2	0-5kV	2.0A	4.0A
KV8-2500/2	0-8kV	1.25A	2.5A
KV10-2000/2	0-10kV	1.0A	2.0A
KV12-1600/2	0-12kV	0.8A	1.6A
KV15-1200/2	0-15kV	0.6A	1.2A

Ratings

Other voltages up to 15kV are available—please contact us to discuss your requirements.

Metering

The output voltage and current are metered using a true RMS metering circuit. The output voltage measurement is taken from a divider on the output and will give accurate results regardless of load type.

Customisation

Certain aspects of the design can be customised at extra cost including HV & supply lead lengths,

Unit	kV meter full scale	kV meter resolution	kV meter accuracy
KV3-7000/2	3.000kV	1V	0.8%±6d
KV5-4000/2	5.000kV	1V	0.8%±6d
KV8-2500/2	8.000kV	1V	0.8%±6d
KV10-2000/2	10.00kV	0.01kV	0.8%±6d
KV12-1600/2	12.00kV	0.01kV	0.8%±6d
KV15-1200/2	15.00kV	0.01kV	0.8%±6d

Unit	mA meter full scale	mA meter resolution	mA meter accuracy
KV3-7000/2	7.000A	1mA	0.8%±6d
KV5-4000/2	4.000A	1mA	0.8%±6d
KV8-2500/2	2.500A	1mA	0.8%±6d
KV10-2000/2	2.000A	1mA	0.8%±6d
KV12-1600/2	1.600A	1mA	0.8%±6d
KV15-1200/2	1.200A	1mA	0.8%±6d

output voltage and supply voltage.

Control

The output voltage is set by a continuously variable output control with a zero volt interlock - the output may only be switched on with the control in the zero position. The output voltage is switched on and off by illuminated push button switches.

The mains supply switch for the unit is a key operated switch. The key is trapped in the switch in the 'on' position.

Optional Test Timer

The HV trolley2 may optionally be supplied with a test timer (this must be specified at time of ordering, and cannot be retro-fitted). The following times are selectable via a switch: 5, 10, 15, 20 and 30 seconds and 1, 2, 3, and 5 minutes. An alarm sounds at the end of the test time.

Supply Requirements

Option 1 400V ±10% 50/60Hz 2ph 22kVA max

Option 2 230V ±10% 50/60Hz 1ph 22kVA max

The unit is fitted with a 5m supply lead and 5 or 10m interconnecting leads.

Protection and Safety

The output of the units are protected by variable electronic trips monitoring the output current and a fixed over-current trip on the primary of the output transformer. The variable trip is adjustable in 10% steps between 10% and 110% of the rated output current. The input and control supplies are protected by fuses.

An emergency stop switch is fitted to the unit.

The HV trolley2 series are designed to meet the requirements of BS EN61010. The unit must be installed in a high voltage test area complying with the requirements of BS EN50191.

An earth terminal is provided on the unit which must be connected to a low impedance local earth.

Interlock Circuits

Two interlock circuits are provided on the HV trolley2 test systems. A zero voltage interlock is fitted which prevents the HV output being energised unless the output voltage control is in the zero position. An external interlock circuit is also provided, allowing the fitting of external emergency off buttons and test cage door interlocks.

Temperature Range

Storage -20°C to 60°C **Operating** 0°C to 45°C

Unit	Dimensions	Weight
Control unit	660 x 400 x 740mm	115kg
HV transformer	660 x 400 x 740mm	130kg

Standard Accessories

1 x 5m earth lead terminated in croc clip

1 x 5m earth lead for connection to local earth

PT18-10 mk3 / PT30-10 mk3

High Voltage DC Cable Test Systems



PT30-10 mk3

Features

- $\pm 18\text{kVDC}$ output (PT18-10 mk3)
- $\pm 30\text{kVDC}$ output (PT30-10 mk3)
- 10mA output capability
- Both voltage and current metered on HV outputs
- Automatic earth system for dumping capacitive loads
- HV output plug & socket system
- Key operated supply switch to prevent unauthorised operation
- Automatic mains voltage selection
- Visual indication of test piece failure
- Zero Volt interlock

T&R Test Equipment is a market leader in the field of protection test equipment. The range includes primary and secondary current injection equipment up to 6000A, voltage sources, micro-ohmmeters and high voltage test systems up to 100kV.

The PT18-10 mk3 and PT30-10 mk3 high voltage DC test sets are designed to perform tests on installed cable and jointing systems. The units have a variable output voltage with a maximum of $\pm 18\text{kVDC}$ (PT18-10 mk3) or $\pm 30\text{kVDC}$ (PT30-10 mk3). Both units have a maximum charging capability of 10mA. A zero-volt interlock is fitted that prevents the output being switched on unless the output control is at zero.

The units include an automatic load discharge system that discharges the cable under test when the output is switched off or a breakdown occurs. The internal dumping system can discharge a maximum of 2.5kJ on each output, corresponding to 10mF at 18kV or 4mF at 30kV. In the event of a test object failure, the overload circuit will automatically switch off the output voltage and earth the output via the internal discharge circuit. A manual discharge probe is also supplied as standard with both units, allowing higher load capacitances to be safely discharged.

The mk3 units introduce automatic 115/230V mains voltage selection, allowing easy transition between site voltages.

The output voltage is metered by two large, linear, analogue instruments marked 0-20kV (PT18-10 mk3) or 0-30kV (PT30-10 mk3).

Test object current is metered by two further analogue instruments with 0-10 scale marking. The meters read 0-10mA directly, or 0-1mA when the $\div 10$ push button is operated. The HV output from both units use a high quality plug and socket system, allowing for easy cable replacement.



PT18-10 mk3

The PT18-10 mk3 and PT30-10 mk3 are part of a comprehensive range of AC & DC high voltage systems available from T&R Test Equipment. The line-up includes cable test sets from $\pm 18\text{kV}$ to $\pm 30\text{kV}$ DC and pressure test systems up to 100kVac.

PT18-10 mk3 & PT30-10 mk3 Specifications

Output

All of the PT series cable test systems have high quality high voltage output connectors, and are supplied with detachable, partially screened output cables.

Unit type	Voltage	Continuous	5 minutes
PT18-10 mk3	0 to ±18kV	5mA	10mA
PT30-10 mk3	0 to ±30kV	5mA	10mA

The above intermittent on times must be followed by an off time of 15 minutes, and is based on an ambient temperature of 25°C.

Metering

The positive and negative output voltages on the PT series are metered on the HV output by separate analogue instruments.

Unit	Range	Accuracy
PT18-10 mk3	0-20kV	±1.5% of full scale
PT30-10 mk3	0-30kV	±1.5% of full scale

The output current on both of the outputs is metered by a dual range analogue instrument. The 1mA range is selected by the ±10 pushbutton adjacent to the mA meter.

Unit	Range	Accuracy
PT18-10 mk3	10mA	±2.5% of full scale
	1mA	±2.5% of full scale
PT30-10 mk3	10mA	±2.5% of full scale
	1mA	±2.5% of full scale

Overload Protection

The PT18-10 and PT30-10 are protected by an overload trip on the output that operates at 12mA.

Load Discharge System

The PT18-10 mk3 and PT30-10 mk3 are fitted with an automatic internal load discharge system that grounds the load via a 20kW resistor on each output when the output is switched off. The discharge system is rated to dissipate 2.5kJ once every 15 minutes on each output. The PT18-10 mk3 can discharge a maximum load capacitance of 10mF per output from 18kV, and the PT30-10 mk3 can discharge a maximum load capacitance of 4mF per output from 30kV.

Unit	PT18-10 mk3	PT30-10 mk3
Maximum discharge energy	2.5kJ	2.5kJ
Maximum discharge capacitance from unit max output voltage	10mF	4mF

The PT series units are supplied with a DP20 or DP40 manual discharge probe to allow the discharge of higher capacitance loads.

	PT18-10 mk3	PT30-10 mk3
Discharge probe supplied	DP20	DP40
Discharge probe max voltage	20kV	40kV
Resistance	30kW	60kW
Maximum discharge energy	3.6kJ	7.2kJ
Maximum discharge capacitance from DP max rated voltage	15mF	11mF

Supply Requirements

PT18-10 mk3 115V/230V±10% auto-selecting
50/60Hz 1ph 600VA max

PT30-10 mk3 115V/230V±10% auto-selecting
50/60Hz 1ph 750VA max

Protection and Safety

The output of the unit is protected by an overload trip, and the input and control supplies are protected by fuses.

The PT18-10 mk3 and PT30-10 mk3 are designed to meet the requirements of BS EN61010.

An earth terminal is provided on the units which must be connected to a low impedance local earth (lead not supplied as standard).

Temperature Range

Storage -20°C to 60°C **Operating** 0°C to 45°C

Dimensions

PT18-10 mk3 471 x 144 x 362mm 17kg unit only
(25kg including bag & leads)

PT30-10 mk3 471 x 191 x 362mm 25kg unit only
(32kg including bag & leads)

Weight

Standard Accessories

Both units: Supply lead, spare fuse, operating manual, 5m HV output leads, 5m output earth lead

PT18-10 mk3 DP20 discharge probe, carry case, lead bag

PT30-10 mk3 DP40 discharge probe, carry case including space for leads

Optional Accessories

	PT18-10 mk3 part No.	PT30-10 mk3 part No.
10m HV leads	A063-193	A064-111
10m earth lead	A064-112	A064-112
15m HV leads	A063-172	A064-100
15m earth lead	A064-101	A064-101
20m HV leads	A064-156	A064-156
20m earth lead	A064-157	A064-157



DP20 Discharge probe

DMO200

Digital Micro-Ohmmeter with USB storage



Features

- Clear and simple user interface
- 1-200A DC Test Current <2.5% ripple
- 0.1μΩ Resolution
- USB Test Data storage
- 200A for 15 minutes with 15 minutes off
- 100A continuous current
- Colour back-lit LCD display
- Programmable test current
- 90-264V Universal supply voltage
- Thermal and over-current protection
- Portable in sturdy case
- Lightweight (6.9kg)
- High quality 3m lead set as standard

T&R Test Equipment is a market leader in the field of power test equipment.

The DMO200 is a 200A micro-ohm meter. It is simple to operate and automatically maintains desired output current. Output current, voltage and resistance are all displayed simultaneously. The DMO200 uses a four wire Kelvin connection to measure low resistance. The resistance is calculated from the test current and sense voltage.

The unit can output any current from 1A to 200A and has the option of three pre-programmable test currents, which can be selected at any time. The unit is designed to comply with BSEN61010 and is CE marked.

Storing results

The DMO200 is supplied with a USB memory key and USB keyboard for storing annotated results. To enter or edit a comment press the COMMENT/MENU button. The comment can then be edited using the keyboard. This comment is stored with each result until a new comment is entered. Each time the output of the unit is switched off, the readings from the unit are saved to the USB memory key in CSV format along with the date, time and your comment.

	A	B	C	D	E	F	G	H	I	J
1	DMO200	V1.00	C01							
2	Time	Date	Current	V	ohm	Re: Comment				
3	10:00:00	10/05/2016	200	2.00E-04	1.00E-06	Y South switchyard breaker 3 phase A				
4	10:01:10	10/05/2016	200	2.04E-04	1.02E-06	Y South switchyard breaker 3 phase B				
5	10:02:13	10/05/2016	200	2.02E-04	1.01E-06	Y South switchyard breaker 3 phase C				
6	10:00:00	10/05/2016	200	2.00E-04	1.00E-06	Y South switchyard breaker 4 phase A				
7	10:01:10	10/05/2016	200	2.04E-04	1.02E-06	Y South switchyard breaker 4 phase B				
8	10:02:13	10/05/2016	200	2.02E-04	1.01E-06	Y South switchyard breaker 4 phase C				
9										

The CSV file can be opened with any spreadsheet program such as Microsoft Excel™ or similar application.

Test Limits

The DMO200 comes with the option of applying upper and lower pass limits for resistance and length of test for production line applications.

There is the option for up to three limit test setups each with their own resistance limits, and test current times. When the current has been set and the pre-set time has elapsed a pass or fail indication is shown.

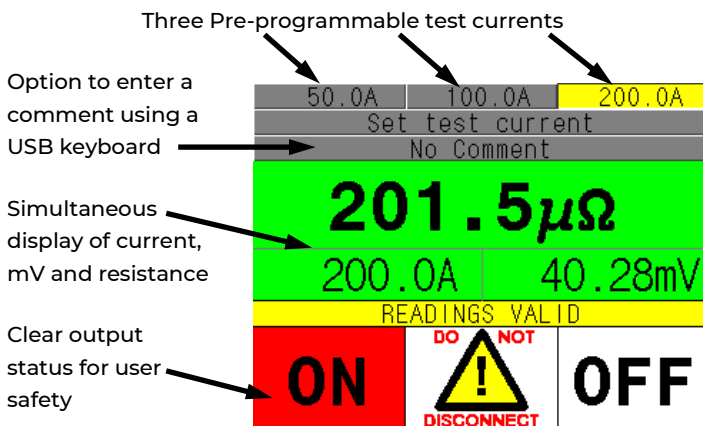

Main Output

The main output allows for currents up to 200A.

Range	Continuous	15 minutes
5VDC	100A	200A

The above intermittent ON time must be followed by an OFF time of 15 minutes, based on an ambient temperature of 25°C.

Metering

The output is metered by a true RMS digital system. Whenever the output is turned off, the current reading is held on the display.

Range	Resolution	Accuracy
1.0 - 200.0A	0.1A	±0.5%rdg±1d

A current trip is automatically detected.

Sense Voltage Inputs

Maximum measurement voltage is 5VDC.

Range	Resolution	Accuracy
0-9.999mV	0.001mV	±0.5%rdg±5d
10.00-99.99mV	0.01mV	±0.5%rdg±5d
100.0-999.9mV	0.1mV	±0.5%rdg±5d
1.000-5.000V	1mV	±0.5%rdg±5d

Resistance accuracy

The calculated resistance accuracy is:

Range	Resolution	Accuracy
50-200A	Full Scale	±1%rdg±2d
10-49A	Full Scale	±1%rdg±10d
5-9.9A	Full Scale	±1%rdg±20d
1-4.9A	Full Scale	±1.5%rdg±20d

Lead Set Specifications

The DMO200 is supplied with a lead set including:
2 x 3m 95mm² output leads with large current clamps,
1 x 3m voltage sense leads, 1 x 5m Earth lead,
1 x 2.5m Mains supply lead.

Supply Requirements

The unit is available for operation from:
90-264Vac 50/60Hz 1ph 3800VA

RS232

An RS232 port is provided to allow connection of a printer or PC. A PC connection allows for remote control of the output current and the recording of test results.

Temperature Range

Storage -20°C to 60°C **Operating** 0°C to 45°C

Accessories

Operating manual, output lead set, mains lead, earth lead, USB memory key, USB keyboard.

Optional Accessories

DMO200 current clamp	Part No. A224-0001
Output/sense extension 3m in plastic case	Part No. A231-0004
Output/sense extension 5m in plastic case	Part No. A231-0005
Output/sense extension 10m in plastic case	Part No. A231-0006

Dimensions

360 x 290 x 165mm

Weight

6.9kg

Example Applications

Busbar Joint Resistance

The DMO200 is ideal for measuring busbar joint resistance. Before making connections ensure that the supply is off and necessary earths have been applied. Connect the high current leads to the busbar, ensuring that the joint resistance to be measured is in the circuit. Connect the sense leads as close as possible to the joint to be measured. Select the desired test current using one of the preset test currents (or use the adjust knob to set a custom test current). Switch the output ON, and the current rises to the preset current. Switch the output OFF, the reading is held on the display.

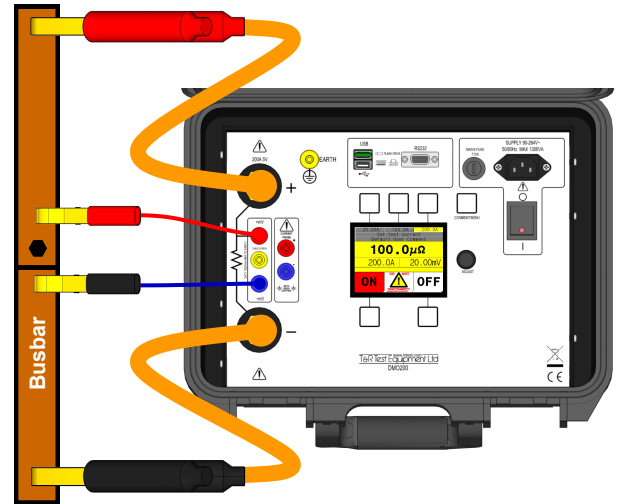

Circuit Breaker Contact Resistance

The DMO200 is suited to all low resistance measurements on power systems, and is particularly suited to measuring contact resistances on substation circuit breakers, isolators and grounding equipment. The unit has a powerful output capable of driving 200A

through 20m output leads to reach the contacts of even the largest circuit breakers. Optional lead extensions are available which extend the high current and sense leads by 3, 5 or 10m.

Accurate measurements on circuit breakers, isolators and grounding links with both sides earthed are simple with the optional current clamp. This allows the current flowing through the earthing equipment to be subtracted from the test current.

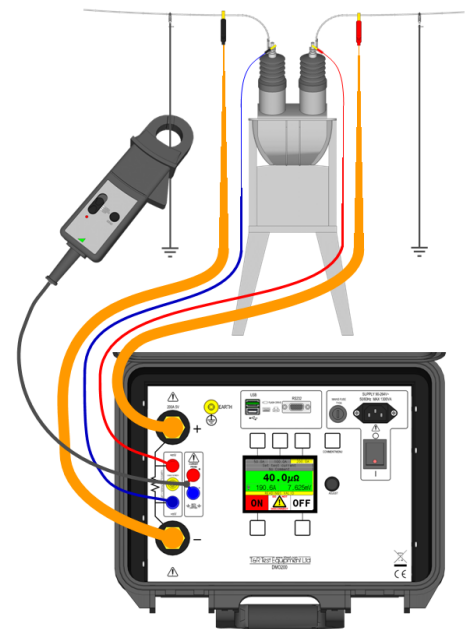

DMO600

Digital Micro-Ohmmeter with USB storage



Features

- Clear and simple user interface
- 10-600A DC Test Current
- 0.1 $\mu\Omega$ —5 Ω Resistance
- USB Test Data storage
- 600A for 2 minutes with 15 minutes off
- 200A continuous current
- Colour LCD display
- Programmable test current
- 90-264V supply voltage
- Thermal and over-current protection
- Portable, sturdy case
- Output ripple is <2.5%
- High quality 3m lead set as standard

T&R Test Equipment is a market leader in the field of power test equipment.

The DMO600 is a 600A micro-ohm meter. It is simple to operate, and automatically maintains desired output current. Output current, voltage and resistance are all displayed simultaneously. The DMO600 uses a four wire Kelvin connection to measure low resistance. The resistance is calculated from the test current and sense voltage.

The unit can output any current from 10A to 600A, and has the option of three pre-programmable test currents, which can be selected at any time. The unit is designed to comply with BSEN61010, and is CE marked.

Storing results

The DMO600 is supplied with a USB memory key and USB keyboard for storing annotated results. To enter or edit a comment tap the COMMENT/MENU button. The comment can then be edited using the keyboard. This comment is stored with each result until a new comment is entered. Each time the output of the unit is switched off the readings from the unit are saved to the USB memory key in CSV format along with the date, time and your comment.

1	A	B	C	D	E	F	G	H	I	J
2	DMO600	V1.00	C01							
3	Time	Date	Current	V	ohm	Re.	Comment			
4	10:00:00	10/05/2016	600	2.00E-04	1.00E-06	Y	South switchyard breaker 3 phase A			
5	10:01:10	10/05/2016	600	2.04E-04	1.02E-06	Y	South switchyard breaker 3 phase B			
6	10:02:13	10/05/2016	600	2.02E-04	1.01E-06	Y	South switchyard breaker 3 phase C			
7	10:00:00	10/05/2016	600	2.00E-04	1.00E-06	Y	South switchyard breaker 4 phase A			
8	10:01:10	10/05/2016	600	2.04E-04	1.02E-06	Y	South switchyard breaker 4 phase B			
9	10:02:13	10/05/2016	600	2.02E-04	1.01E-06	Y	South switchyard breaker 4 phase C			

Three Pre-programmable test currents

Option to enter a comment using USB keyboard

Simultaneous display of current, mV and resistance.

Clear output status for user safety

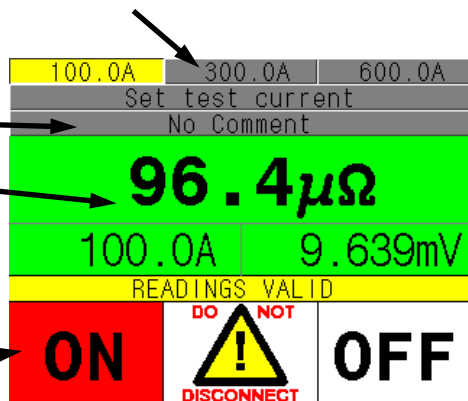

The CSV file can be opened with any spreadsheet program such as Microsoft Excel™ or similar application.

Test Limits

The DMO600 comes with the option of applying upper and lower pass limits for resistance and length of test for production line applications.

There is the option for up to three limit test setups each with their own resistance limits, and test current times. When the current has been set and the pre-set time has elapsed a pass or fail indication is shown.

DMO600 Specification

Main Output

The main output allows for currents up to 600A.

Range	Continuous	2 minutes
5VDC	200A	600A

The above intermittent on times must be followed by an off time of 15 minutes, and are based on an ambient temperature of 25°C.

Metering

The output is metered by a digital true RMS system. Whenever the output is turned off, the current reading is held on the display.

Range	Resolution	Accuracy
10.0-600.0A	0.1A	$\pm 0.5\%rdg \pm 1d$

A current trip is automatically detected.

Sense Voltage Inputs

Maximum measurement voltage is 5VDC

Resistance accuracy

The calculated resistance accuracy is:

Range	Resolution	Accuracy
0-9.999mV	0.001mV	$\pm 0.5\%rdg \pm 5d$
10.00-99.99mV	0.01mV	$\pm 0.5\%rdg \pm 5d$
100.0-999.9mV	0.1mV	$\pm 0.5\%rdg \pm 5d$
1.000-5.000V	0.001V	$\pm 0.5\%rdg \pm 5d$

Range Resistance	Accuracy
100-600A Full Scale	$\pm 1\%rdg \pm 2d$
10-99A Full Scale	$\pm 1.5\%rdg \pm 10d$

Lead Set Specifications

The DMO600 is supplied with a lead set including:

2 x 3m 95mm² output leads with large current clamps.

1 x 3m voltage sense leads, 1 x 5m Earth & mains lead,

Supply Requirements

The unit is available for operation from:

90-264Vac 50/60Hz 1ph 3800VA

RS232

An RS232 port is provided to allow connection of a printer or PC. A PC connection allows for remote control of the output current, and recording of test results.

Temperature Range

Storage -20°C to 60°C Operating 0°C to 45°C

Accessories

Operating manual, output lead set, mains lead, earth lead, USB memory key, USB keyboard.

Optional Accessories

DMO600 current clamp	Part No.	A224-0001
Output/sense extension 3m in plastic case	Part No.	A231-0004
Output/sense extension 5m in plastic case	Part No.	A231-0005
Output/sense extension 10m in plastic case	Part No.	A231-0006

Dimensions

	Weight
Peli case: 560 x 456 x 265mm	19.7kg
Metal case: 380 x 314 x 221mm	15.8kg

Example Applications

Busbar Joint Resistance

The DMO600 is ideal for measuring busbar joint resistance. Before making connections ensure that the supply is off and necessary earths have been applied. Connect the high current leads to the busbar, ensuring that the joint resistance to be measured is in the circuit. Connect the sense leads as close as possible to the joint to be measured. Select the desired test current using one of the preset test currents (or use the adjust knob to set a custom test current). Switch the output ON, and the current rises to the preset current. Switch the output OFF again, and the reading is held on the display.

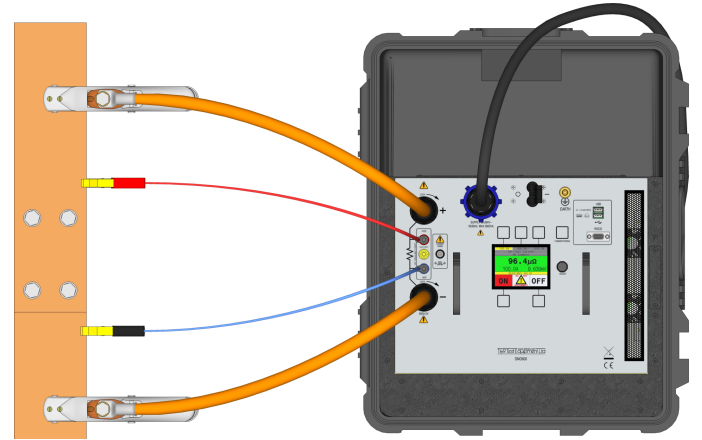

Circuit Breaker Contact Resistance

The DMO600 is suited to all low resistance measurements on power systems, and is particularly suited to measuring contact resistances on substation circuit breakers, isolators and grounding equipment. The unit has a powerful output capable of driving 600A through 20m output leads to reach the contacts of even the largest circuit breakers. Optional output lead extensions are available which extend the high current and sense leads by 3, 5 or 10m.

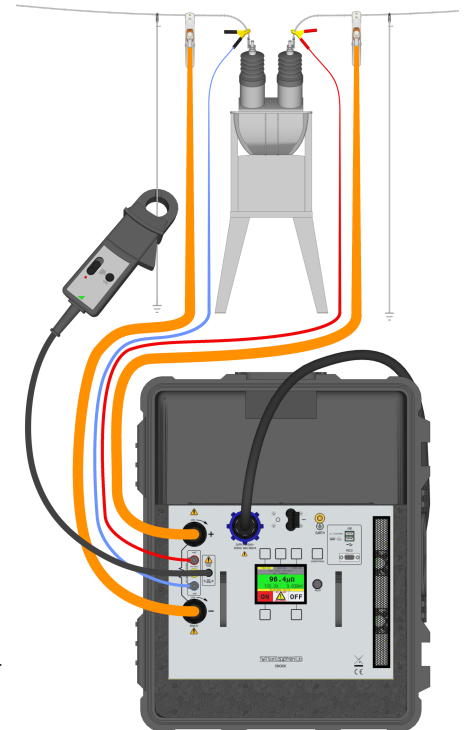

Accurate measurements on circuit breakers, isolators and grounding links with both sides earthed are simple with the optional current clamp. This allows the current flowing through the earthing equipment to be subtracted from the test current.

COMING
SOON!

TPT9000

Transformer Polarity Tester



Features

- Fast polarity testing of both current and voltage transformers
- Smart detection of incorrect connection
- Light weight
- Handheld
- Powered by a single 9V battery
- Fused test leads for safety and protection
- Built in battery monitor
- Proving unit included in the kit as standard